

## TECHNICAL BULLETIN

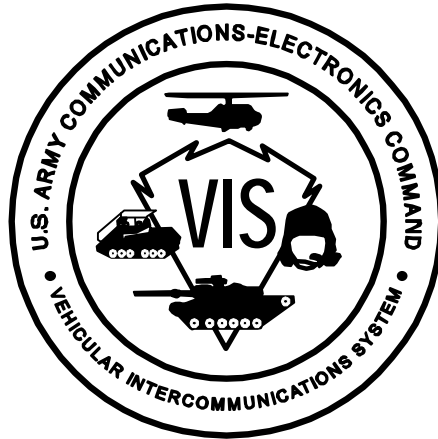

**INSTALLATION INSTRUCTIONS FOR  
INTERCOMMUNICATION SET, VEHICULAR  
AN/VIC-3(V)2  
(NSN 5830-01-395-7448) (EIC: NA)  
IN A  
TANK, COMBAT, FULL TRACKED, M1A2**

Approved for public release; distribution is unlimited.

DESTRUCTION NOTICE -- Destroy by any method that will prevent disclosure of contents or reconstruction of the document.

---

**HEADQUARTERS, DEPARTMENT OF THE ARMY**

**1 JUNE 2000**





**5**

SAFETY STEPS TO FOLLOW IF SOMEONE IS THE VICTIM OF ELECTRICAL SHOCK

**1**

DO NOT TRY TO PULL OR GRAB THE INDIVIDUAL

**2**

IF POSSIBLE, TURN OFF THE ELECTRICAL POWER

**3**

IF YOU CANNOT TURN OFF THE ELECTRICAL POWER, PULL, PUSH, OR LIFT THE PERSON TO SAFETY USING A DRY WOODEN POLE OR A DRY ROPE OR SOME OTHER INSULATING MATERIAL

**4**

SEND FOR HELP AS SOON AS POSSIBLE

**5**

AFTER THE INJURED PERSON IS FREE OF CONTACT WITH THE SOURCE OF ELECTRICAL SHOCK, MOVE THE PERSON A SHORT DISTANCE AWAY AND IMMEDIATELY START ARTIFICIAL RESUSCITATION

**WARNING**

**HIGH VOLTAGE**

IS USED IN THE OPERATION OF THIS EQUIPMENT.

**DEATH ON CONTACT**

MAY RESULT IF PERSONNEL FAIL TO OBSERVE SAFETY PRECAUTIONS.

NEVER WORK ON ELECTRONIC EQUIPMENT UNLESS THERE IS ANOTHER PERSON NEARBY WHO IS FAMILIAR WITH THE OPERATION AND HAZARDS OF THE EQUIPMENT AND WHO IS COMPETENT IN ADMINISTERING FIRST AID. WHEN THE TECHNICIAN IS AIDED BY OPERATORS, HE MUST WARN THEM ABOUT DANGEROUS AREAS.

BE CAREFUL NOT TO CONTACT HIGH-VOLTAGE CONNECTIONS OF THE AC INPUT CONNECTIONS WHEN INSTALLING OR OPERATING THIS EQUIPMENT.

WHENEVER THE NATURE OF THE OPERATION PERMITS, KEEP ONE HAND-AWAY FROM THE EQUIPMENT TO REDUCE THE HAZARD OF CURRENT FLOWING THROUGH VITAL ORGANS OF THE BODY.

**WARNING**

DO NOT BE MISLED BY THE TERM "LOW VOLTAGE". POTENTIALS AS LOW AS 30 VOLTS MAY CAUSE DEATH UNDER CERTAIN CONDITIONS.

FOR ARTIFICIAL RESPIRATION, REFER TO FM 21-11.

**WARNING**

WHEN LISTENING TO THE VIS RADIO HEADSET WITH THE OPERATOR VOLUME CONTROLS SETTING IN THE RED ZONE CLICK STOP AT A FULL ON VOLUME SETTING, EXTREME CAUTION MUST BE EXERCISED TO PREVENT NOISE-INDUCED HEARING LOSS. EXPOSURES TO RADIO SIGNALS IN THE FULL ON POSITION BEYOND 45 SECONDS MAY CAUSE HEARING LOSS. ANY PROLONGED EXPOSURE IN THE FULL ON VOLUME CONTROL SETTING REQUIRES THE USE OF A SINGLE HEARING PROTECTIVE DEVICE IN EACH EAR.

**WARNING**

ALKALINE BATTERIES CONTAIN CAUSTIC KOH ELECTROLYTE, WHICH MAY LEAK IF THE BATTERY IS ABUSED. KOH IS A STRONG ALKALI SIMILAR TO CAUSTIC SODA (SODIUM HYDROXIDE). SERIOUS CHEMICAL BURNS CAN RESULT IF ELECTROLYTE COMES INTO CONTACT WITH THE SKIN OR EYES. IF THE BATTERY ELECTROLYTE GETS INTO YOUR EYES, IT CAN CAUSE SEVERE DAMAGE AND/OR BLINDNESS.

DO NOT TRY TO NEUTRALIZE CAUSTIC ELECTROLYTE WITH VINEGAR OR ANY OTHER ACIDIC SOLUTIONS. NEUTRALIZATION WILL DO MORE HARM THAN GOOD, AS IT WILL TRAP CAUSTIC UNDER THE SKIN, PREVENTING IT FROM COMING OUT. FLUSH WITH COPIOUS AMOUNTS OF COOL WATER.

**WARNING**

DISCONNECTING OR BYPASSING THE VEHICULAR INTERCOMMUNICATION SYSTEM (VIS) ALARM CABLE CONNECTED TO THE DRIVER'S FULL FUNCTION CREW STATION (FFCS) BY THE VEHICLE CREWMAN IS PROHIBITED. SUCH ACTION MAY RESULT IN INJURY OR DEATH. EQUIPMENT DAMAGE MAY ALSO RESULT. THIS CABLE ENABLES THE VEHICLE HAZARD WARNING TONES TO BE INSERTED DIRECTLY INTO THE INTERCOM SYSTEM, SO THAT THESE WARNING TONES CAN BE INSTANTLY HEARD BY ALL OF THE VEHICLE CREWMEMBERS. ONLY THE UNIT MAINTAINER IS AUTHORIZED TO REMOVE AND REPLACE THE ALARM CABLE. REFER TO THE APPROPRIATE VIS TECHNICAL PUBLICATIONS FOR OPERATOR, INSTALLATION, AND MAINTENANCE INSTRUCTIONS.



CHANGE

HEADQUARTERS,  
DEPARTMENT OF THE ARMY  
WASHINGTON, D.C., 1 MAY 2004

No. 1

**INSTALLATION INSTRUCTIONS FOR  
INTERCOMMUNICATION SET, VEHICULAR  
AN/VIC-3(V)2  
(NSN 5830-01-395-7448) (EIC: NA)  
IN A  
TANK, COMBAT, FULL TRACKED, M1A2**

TB 11-5830-262-20-2, 1 June 2000, is changes as follows:

1. New or changed text is indicated by a vertical bar in the margin of the page.
2. Remove old pages and insert new pages:

**Remove Pages**

c/(d blank)  
A(B blank)  
29/30  
none  
31 thru 33/(34 blank)

**Insert Pages**

c/(d blank)  
A/(B blank)  
29/30  
30.1/(30.2 blank)  
31 thru 34

3. File this sheet in front of the publication for reference purposes.
4. This change supercedes Interim Change 001, 1 May 2003.

**APPROVED FOR PUBLIC RELEASE; DISTRIBUTION IS UNLIMITED.**

By Order of the Secretary of the Army:

Official:

**PETER J. SCHOOMAKER**  
*General, United States Army*  
*Chief of Staff*

  
JOEL B. HUDSON  
*Administrative Assistant to the*  
*Secretary of the Army*  
0412605

DISTRIBUTION:

To be distributed in accordance with the initial distribution number (IDN) 369721 requirements for TB 11-5830-263-20-2.



LIST OF EFFECTIVE PAGES/WORK PACKAGES

Dates of issue for the original manual and changed pages/work packages are:

Original            1 June 2000  
 Change 1           1 May 2004

TOTAL NUMBER OF PAGES IS 62, CONSISTING OF THE FOLLOWING:

<b>Page/WP No.</b>	<b>*Change No.</b>	<b>Page/WP No.</b>	<b>*Change No.</b>
Cover/blank	0	32 thru 34	1
a/b	0	35 thru 37/(38 blank)	0
c/d blank)	1	DA 2028 (8 pages)	0
i thru iii/(iv blank)	0	Authentication/blank	0
1 thru 29	0	Blank/Cover	0
30	1		
30.1/(30.2 blank)	1		
31	0		

\* Zero in this column indicates an original page.



**INSTALLATION INSTRUCTIONS FOR  
INTERCOMMUNICATION SET, VEHICULAR  
AN/VIC-3(V)2  
(NSN 5830-01-395-7448) (EIC: NA)  
IN A  
TANK, COMBAT, FULL TRACKED, M1A2**

**REPORTING ERRORS AND RECOMMENDING IMPROVEMENTS**

You can help improve this manual. If you find any mistakes, or if you know of a way to improve the procedures, please let us know. Mail your letter, DA Form 2028 (Recommended Changes to Publications and Blank Forms) or DA Form 2028-2 located in back of this manual direct to: Commander, US Army Communications-Electronics Command and Fort Monmouth, ATTN: AMSEL-LC-LEO-D-CS-CFO, Fort Monmouth, New Jersey 07703-5007. The fax number is 732-532-1413, DSN 992-1413. You may also email your recommendations to AMSEL-LC-LEO-PUBS-CHG@cecom3.monmouth.army.mil

In either case a reply will be furnished direct to you.

APPROVED FOR PUBLIC RELEASE; DISTRIBUTION IS UNLIMITED.

**TABLE OF CONTENTS**

<b>SUBJECT</b>	<b>PAGE</b>
<b>SECTION I. INTRODUCTION .....</b>	<b>1</b>
1.1 SCOPE.....	1
1.2 GENERAL INFORMATION.....	1
1.3 CONSOLIDATED INDEX OF ARMY PUBLICATIONS .....	2
1.4 MAINTENANCE FORMS, RECORDS, AND REPORTS .....	2
1.5 CORROSION PREVENTION AND CONTROL .....	2
<b>SECTION II. PREPARATION FOR INSTALLATION.....</b>	<b>3</b>
2.1 PREPARING THE VEHICLE .....	3
2.2 EXPENDABLE/DURABLE ITEMS .....	4
2.3 TOOLS AND TEST, MEASUREMENT AND DIAGNOSTIC EQUIPMENT .....	4
2.4 VIS COMPONENTS (PARTS LIST) .....	5
2.5 PRE-INSTALLATION STEPS AND PROCEDURES .....	8

**TABLE OF CONTENTS (continued)**

<b>SUBJECT</b>	<b>PAGE</b>
<b>SECTION III. FFCS AND RIT CREW STATION/RADIO SWITCH SETTING PROCEDURES</b> .....	<b>9</b>
3.1 FFCS CREW STATION ADDRESS SWITCH SETTING PROCEDURES .....	9
3.2 RIT RADIO SELECTION SWITCH SETTING PROCEDURES .....	9
<b>SECTION IV. INSTALLATION INSTRUCTIONS</b> .....	<b>10</b>
4.1 EQUIPMENT LOCATION AND SYSTEM CONFIGURATION DIAGRAMS .....	10
4.2 MASTER CONTROL STATION (MCS) INSTALLATION .....	12
4.3 FULL FUNCTION CREW STATION (FFCS) INSTALLATION .....	14
4.4 RADIO INTERFACE TERMINAL (RIT) INSTALLATION .....	20
4.5 MONITOR ONLY STATION (MOS) INSTALLATION .....	20
4.6 LOUDSPEAKER (LS) INSTALLATION .....	20
4.7 VIS CABLING INSTALLATION .....	22
<b>SECTION V. POST-INSTALLATION</b> .....	<b>32</b>
5.1 POST-INSTALLATION CHECKOUT PROCEDURES .....	32
5.2 POST-INSTALLATION OPERABILITY VERIFICATION PROCEDURES .....	33
<b>APPENDIX A - REFERENCES</b> .....	<b>35</b>
A-1. SCOPE .....	35
A-2. FORMS .....	35
A-3. TECHNICAL MANUALS .....	35
A-4. MISCELLANEOUS PUBLICATIONS .....	36

**LIST OF TABLES**

<b>Number</b>	<b>Title</b>	<b>Page</b>
Table 2-1.	Retained Items List.....	3
Table 2-2.	Expendable/Durable Items .....	4
Table 2-3.	Tools and Test, Measurement and Diagnostic Equipment .....	4
Table 2-4.	VIS Components (Parts List).....	5
Table 4-1.	MCS Installation Parts .....	12
Table 4-2.	Loader's FFCS Installation Parts .....	14
Table 4-3.	Gunner's and Commander's FFCS Installation Parts .....	16
Table 4-4.	Driver's FFCS Installation Parts .....	18

**LIST OF FIGURES**

<b>Number</b>	<b>Title</b>	<b>Page</b>
Figure 2-1.	Illustrated Parts List .....	6
Figure 2-2.	Illustrated Parts List - Cables.....	7
Figure 3-1.	FFCS Crew Station Address Switch.....	9
Figure 4-1.	Equipment Location Diagram .....	10
Figure 4-2.	System Configuration Diagram.....	11
Figure 4-3.	MCS Installation.....	13
Figure 4-4.	Loader's FFCS Installation.....	15
Figure 4-5.	Gunner's and Commander's FFCS Installation .....	17
Figure 4-6.	Driver's FFCS Installation .....	19
Figure 4-7.	MCS, Loader's FFCS and Loudspeaker Cabling .....	23
Figure 4-8.	Turret Floor Cable Installation.....	27
Figure 4-9.	Gunner's and Commander's FFCS Cabling .....	29
Figure 4-10.	Driver's FFCS Cabling .....	31



## Section I. INTRODUCTION

### 1.1 SCOPE

This technical bulletin provides installation instructions for the Intercommunication Set, Vehicular AN/VIC-3(V), hereinafter referred to by its common name, VIS (Vehicular Intercommunication System). There are many current and future variations of this system, e.g. AN/VIC-3(V)1, (V)2, etc., designed for specific vehicles and/or platforms, each with its own unique technical bulletin. The version this technical bulletin covers and the vehicle/platform it is being installed in is:

“AN/VIC-3(V)2”

into the

“TANK, COMBAT, FULL TRACKED, M1A2”

The information contained in this technical bulletin is the official authorization to perform the installation of the VIS at the Unit Maintenance Level.

### 1.2 GENERAL INFORMATION

#### a. Reference Publications

There are two manuals associated with the VIS, TM 11-5830-263-10 Operator's Manual, and TM 11-5830-263-20&P Unit Maintenance Manual (Including Repair Parts and Special Tools List (RPSTL)). Additionally, for periodic updated information on the VIS and its specific components refer to the CECOM Supply Bulletin and The Preventive Maintenance Monthly.

#### b. Purpose of Equipment

The AN/VIC-3(V) or VIS is an intercommunication and radio-control system designed for ground mobile combat vehicles. Digital audio enhances speech quality and intelligibility. Headsets that incorporate active noise reduction (ANR) circuitry increase the effectiveness of vehicle communications. They offer increased hearing protection in the noisy environment of combat vehicles.

#### c. Equipment Components

The AN/VIC-3(V) or VIS versions are configured for specific vehicles and/or platforms. When installed in a vehicle/platform it loses its identity. VIS is designed to replace the AN/VIC-1 or -2, in some cases utilizing the existing mounting hardware and brackets used by the AN/VIC-1 or -2. VIS consists of LRU's (Line Replaceable Units (Boxes)) (the type and quantity of which vary depending upon the specific vehicle and/or platform), various types of cables (highway, power, alarm, etc.), headsets (the type and quantity of which vary depending upon the specific vehicle and/or platform), brackets, and mounting hardware (nuts, bolts, screws, etc.) for securing both the LRU's and brackets. Every vehicle/platform contains one Master Control Station (MCS), a number of Full Function Crew Stations (FFCS), and a Permanent Magnet Loudspeaker (LS). Depending upon the vehicle/platform VIS is being installed in, it may also contain Radio Interface Terminal(s) (RIT) and Monitor Only Station(s) (MOS).

### 1.3 CONSOLIDATED INDEX OF ARMY PUBLICATIONS

Refer to the latest issue of DA PAM 25-30 to determine whether there are new editions, changes, or additional publications pertaining to the equipment.

### 1.4 MAINTENANCE FORMS, RECORDS, AND REPORTS

#### a. Reports of Maintenance and Unsatisfactory Equipment

Department of the Army forms and procedures used for equipment maintenance will be those prescribed by DA Pam 738-750, as contained in Maintenance Management Update.

#### b. Reporting of Item and Packaging Deficiencies

Fill out and forward SF364 (Report of Discrepancy (ROD)) as prescribed in AR 735-11-2/DLAR 4140.55/SECNAVINST 4355.18/AFR400-54/MCO 4430.3J.

#### c. Transportation Discrepancy Report (TDR)(SF361)

Fill out and forward Transportation Discrepancy Report (TDR) (SF361) as prescribed in AR 55-38/NAVSUPINST 4610.33C/AFR 75-18/MCO P4610.19D/DLAR 4500.15.

### 1.5 CORROSION PREVENTION AND CONTROL

Corrosion Prevention and Control (CPC) of Army materiel is a continuing concern. It is important that any corrosion problems with this item be reported so that the problems can be corrected and improvements can be made to prevent the problem in the future.

While corrosion is typically associated with rusting of metals, it can also include deterioration of other materials, such as rubber and plastic. Unusual cracking, softening, swelling, or breaking of these materials may be a corrosion problem.

If a corrosion problem is identified, it can be reported using SF 368, Product Quality Deficiency Report (QDR). Use of key words such as "corrosion", "rust", "deterioration", or "cracking" will ensure that the information is identified as a CPC problem.

The form should be submitted to the address specified in DA PAM 738-750, Functional User's Manual for the Maintenance Management System (TAMMS).



**SECTION II. PREPARATION FOR INSTALLATION**

Prior to preparing the vehicle for installation or actually installing the VIS this technical bulletin should be read in its entirety.

**2.1 PREPARING THE VEHICLE**

- a. To prepare the vehicle for installation, ensure that the site includes adequate lighting. Inspect the vehicle for damage that could effect installation. Have any such damage repaired before installing VIS.
  
- b. Installing the AN/VIC-3(V) into the vehicle/platform sometimes requires retaining the existing mounting hardware (and brackets) that were used to secure the AN/VIC-1 or -2 systems being replaced. Table 2-1 lists the items, if any, to be retained prior to installation.

**Table 2-1. Retained Items List**

Item Description and Part Number	Quantity
(None required for this installation)	

**2.2 EXPENDABLE/DURABLE ITEMS**

Table 2-2 lists the Expendable/Durable items the unit or retrofit/installation team should have on hand prior to the installation of the VIS. Refer to the VIS Operator’s TM for specific uses for these items not cited in this technical bulletin.

**Table 2-2. Expendable/Durable Items**

Item No.	National Stock Number	Description	U/M
1.	6850-00-973-9091	Fluid, Penetrating, (01267) DUOL	CN
2.	7920-00-044-9281	Cloth, Cleaning, (81349), MIL-C-85043	BX
3.	6810-00-292-9625	Degreasing Solvent, (83574) PR-146BLUE	QT
4.	6850-00-664-4959	Silicone Compound, (71984), DC 6	GL
5.	7930-00-282-9699	Detergent, General Purpose, (81349), MIL-D-16791	GL
7.	6810-01-075-5546	Isopropyl Alcohol	CN

**2.3 TOOLS AND TEST, MEASUREMENT AND DIAGNOSTIC EQUIPMENT (TMDE)**

Table 2-3 lists the tools, and if required, the TMDE needed for installation of the VIS.

**Table 2-3. Tools and Test, Measurement and Diagnostic Equipment**

NOMENCLATURE	NSN	QUANTITY
Screwdriver, No. 3 Point Phillips, 4 in.	5120-00-234-8912	1
Tool Kit TK101 /G	5180-00-064-5178	1
Pliers, Slip Joint, 1 1/2 in.	5120-01-336-5636	1

**2.4 VIS COMPONENTS (PARTS LIST)**

Table 2-4 lists, with quantities, the Line Replaceable Units (LRU's)(Boxes), Headsets, Cables, Brackets, Mounting Hardware and any other items that will be installed in the vehicle/platform covered by this technical bulletin. This table will be used as a checklist when the pre-installation inventory is conducted. Illustrations (Figures) referenced in Table 2-4 are on the pages immediately following the table. It should be noted that this table does not list parts that need to be retained for reuse from removing the previous AN/VIC-1 or -2 system. Refer to Table 2-1 for those items.

**Table 2-4. VIS Components (Parts List)**

NSN	ITEM DESCRIPTION AND PART NUMBER	QTY IN VIS	SMR CODE	FIGURE *, ITEM NO.
5895-01-382-3221	Master Control Station (MCS), A3205747	1	PAODD	2-1, 1
5830-01-382-3218	Full Function Crew Station (FFCS), A3205746 (Driver's, Spare, FSSgt, FSO, and FSS)	4	PAODD	2-1, 2
5965-01-382-3222	Loudspeaker, Permanent Magnet, LS-688, A3206080	1	PAOOO	2-1, 3
5965-01-397-7542	Headset, CVC Small, A3206101-1	4 Total	PAOOO	2-1, 4
5965-01-398-1551	Headset, CVC Medium, A3206101-2		PAOOO	2-1, 4
5965-01-397-7544	Headset, CVC Large, A3206101-3		PAOOO	2-1, 4
5995-01-392-7323	Cable Assembly, Power, A3206017-7		1	PAOZZ
5995-01-392-6203	Cable Assembly, Highway, A3206018-8	1	PAOZZ	2-2, 6
5995-01-392-9114	Cable Assembly, Highway, A3206018-20	1	PAOZZ	2-2, 6
5995-01-392-7352	Cable Assembly, Highway, A3206018-21	1	PAOZZ	2-2, 6
5995-01-392-7364	Cable Assembly, R/T, A3206019-9	2	PAOZZ	2-2, 7
5995-01-386-9109	Cable Assembly, Bailout, A3206020	4	PAOZZ	2-2, 8
5995-01-392-7325	Cable Assembly, Alarm, A3206118	1	PAOZZ	2-2, 9
5995-01-392-7322	Cable Assembly, Highway/Vehicle, A3206121-4-5	1	PAOZZ	2-2, 10
5995-01-392-7321	Cable Assembly, Highway/Vehicle, A3206120-3-3	1	PAOZZ	2-2, 10
5995-01-393-7694	Cable Assembly, Loudspeaker, A3206193-6	1	PAOZZ	2-2, 11
5995-01-392-0216	Cable Assembly, Loudspeaker, A3206193-30	1	PAOZZ	2-2, 11
Not applicable	Cover Assembly, MCS, A3206103	1	PAOZZ	
Not applicable	Bracket, Mounting, MCS, A3206200	1	PAOZZ	
Not applicable	Plate, Mounting, A3206395	1	PAOZZ	
Not applicable	Bracket, Mounting, Driver's FFCS, A3206122	1	PAOZZ	
Not applicable	Bracket, Loader's FFCS/Loudspeaker, A3206396	1	PAOZZ	
5365-00-783-9035	Strap, Cable, A3206207	6 ft	PAOZZ	
5310-00-081-4219	Washer, Flat, MS27183-12	10	PAOZZ	
5310-00-014-5850	Washer, Flat, MS27183-42	2	PAOZZ	
5305-00-984-6210	Screw, Pan Head, MS35206-263	4	PAOZZ	
5310-00-576-5752	Washer, Lock, MS35333-39	4	PAOZZ	
5310-00-550-1130	Washer, Lock, MS35333-40	2	PAOZZ	
5310-00-167-0721	Washer, Lock, MS35333-41	10	PAOZZ	
5310-00-103-6042	Washer, Flat, MS51412-4A	2	PAOZZ	
5310-00-880-7746	Nut, Hexagon, MS51968-5	10	PAOZZ	
5305-00-225-3839	Bolt, Machine, MS90725-8	2	PAOZZ	
5306-01-411-9027	U-Bolt, NAS3103-6-8	1	PAOZZ	
5310-00-807-1467	Nut, Lock, MS21042-3	2	PAOZZ	
5975-00-133-8696	Strap, Tiedown, MS3367-6-9	14	PAOZZ	
Not applicable	Decal, Reference, A3206460	1	XBOZZ	

\* See Figures 2-1 and 2-2 for illustration of the referenced part(s).

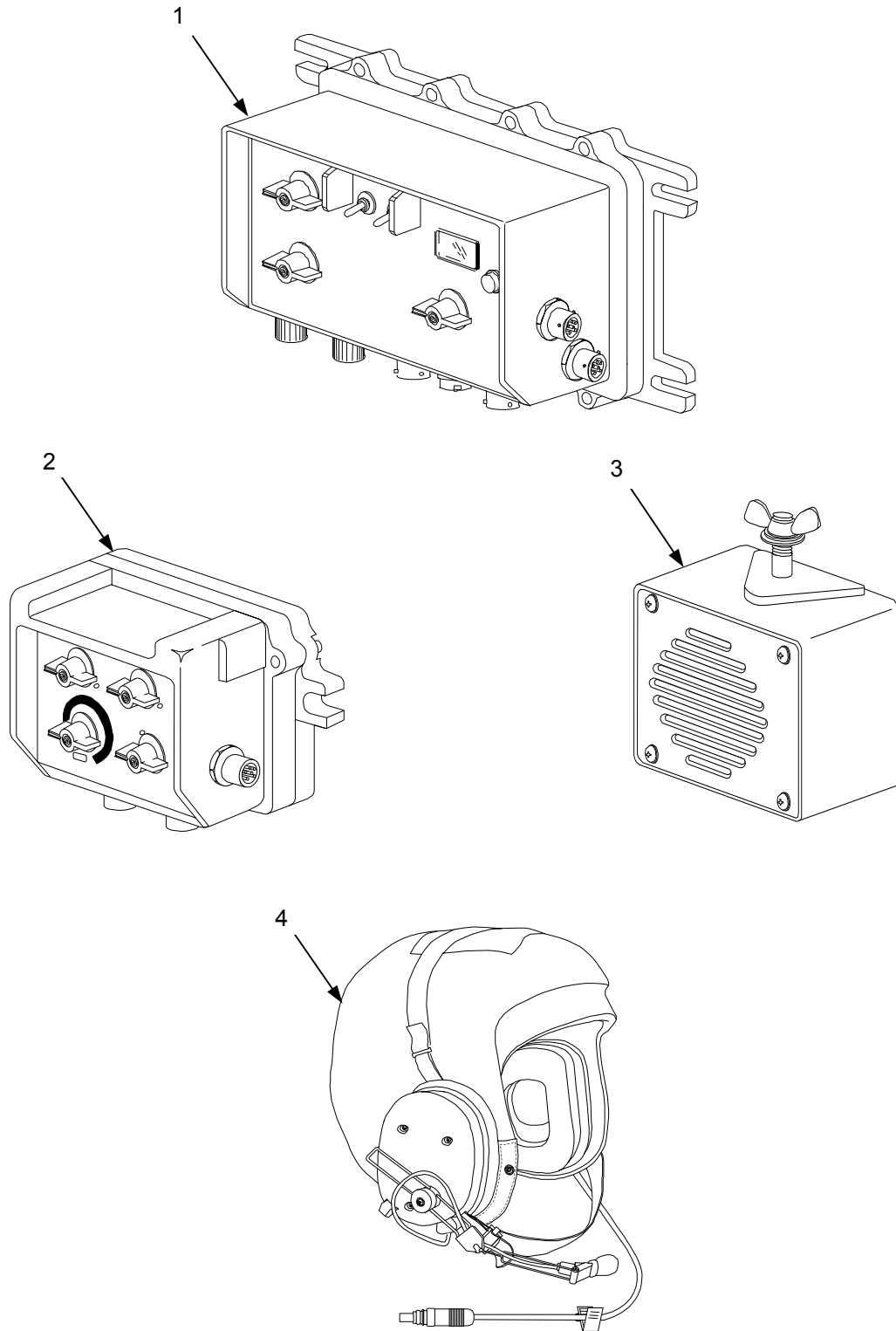

Figure 2-1. Illustrated Parts List

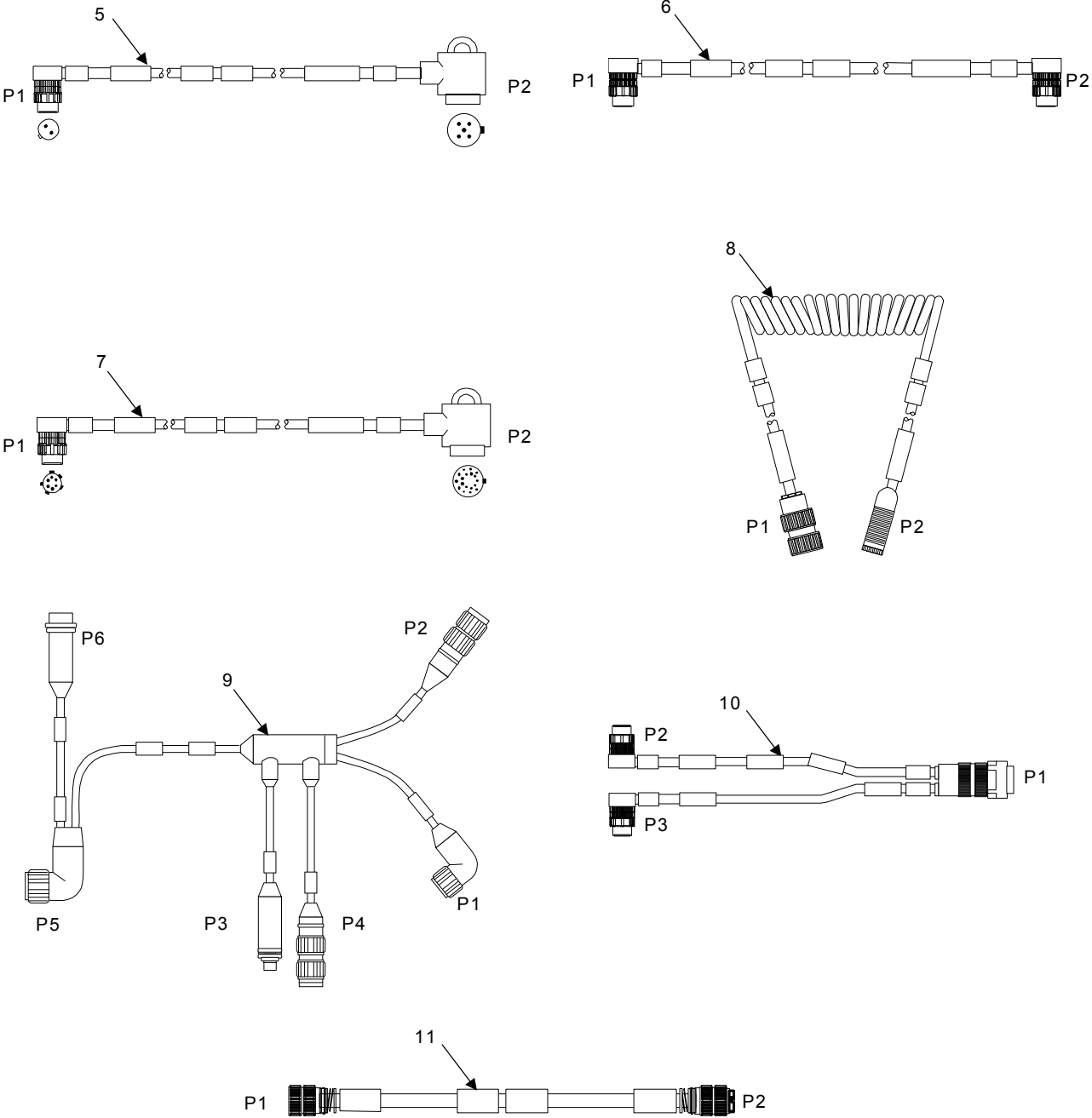

Figure 2-2. Illustrated Parts List - Cables

## 2.5 PRE-INSTALLATION STEPS AND PROCEDURES

- a. Read the technical bulletin in its entirety prior to performing any designated tasks.
- b. Ensure that the expendable/durable items identified in Table 2-2, and the tools and TMDE, if required, identified in Table 2-3 are available for use.
- c. Remove the AN/VIC-1 or -2 system, if present, in preparation of installing the VIS. Refer to Table 2-1 to determine, what, if any, AN/VIC-1 or -2 components need to be retained.
- d. Unpack VIS equipment/components and conduct a complete physical inventory of the items using Table 2-4 as a checklist. Be sure to inspect packaging for evidence of damage and examine each item for damage. If any discrepancies are noted refer to paragraphs 1.4 and 1.5 for the appropriate maintenance documentation to fill out.
- e. Examine the decal provided with the kit. Identify the number of FFCSs and RIT's. Mark the FFCSs and RITs numerically to match the decal (a piece of tape is recommended).
- f. For each FFCS, set the Crew Station Address Switch to the number marked on it. For each RIT, set the Radio Selection Switch to the appropriate radio setting. Refer to Section III for the appropriate procedures to accomplish these tasks.
- g. You are now ready to install the VIS into the vehicle/platform.

### SECTION III. FFCS AND RIT CREW STATION/RADIO SWITCH SETTING PROCEDURES

#### 3.1 FFCS CREW STATION ADDRESS SWITCH SETTING PROCEDURES

Perform the following procedure to change the FFCS Crew Station Address switch setting located on the bottom of the FFCS. Crew Station Addresses are as shown on the Decal.

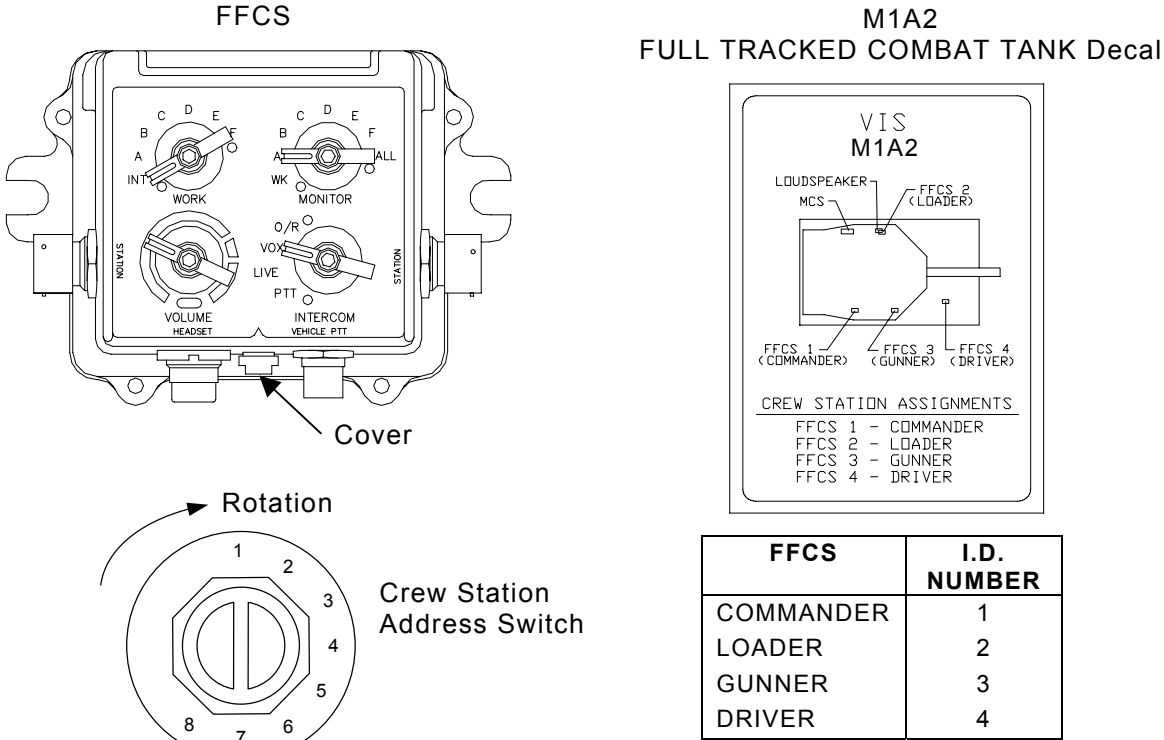

**Figure 3-1. FFCS Crew Station Address Switch**

- a. Rotate switch cover screw counterclockwise (ccw) and remove.
- b. Using a jeweler’s screwdriver, rotate the adjustment screw ccw, until stop is reached. This is the setting for Crew Station #1.
- c. Each click of the switch in a clockwise direction changes the address by one position. For example, with the switch in the full ccw position (Crew Station #1), turning the switch two clicks in a clockwise direction will set the FFCS to Crew Station #3.
- d. The address switch has 8 positions. Crew Station settings are numbered 1 through 6. Position 7 on the switch is the same as position 6. Position 8 on the switch is normally used for testing, however, if the MCS is not functioning correctly, e.g., loss of timing signal (sync pulse), but is supplying power to the rest of the system, setting the switch to position 8 will result in the FFCS putting out a timing signal like the MCS.
- e. When the correct Crew Station address has been set replace switch cover screw and hand tighten.

#### 3.2 RIT RADIO SELECTION SWITCH SETTING PROCEDURES

This vehicle does not contain any RITs.

## SECTION IV. INSTALLATION INSTRUCTIONS

### 4.1 EQUIPMENT LOCATION AND SYSTEM CONFIGURATION DIAGRAMS

The Equipment Location and the System Configuration Diagrams are shown in Figures 4-1 and 4-2.

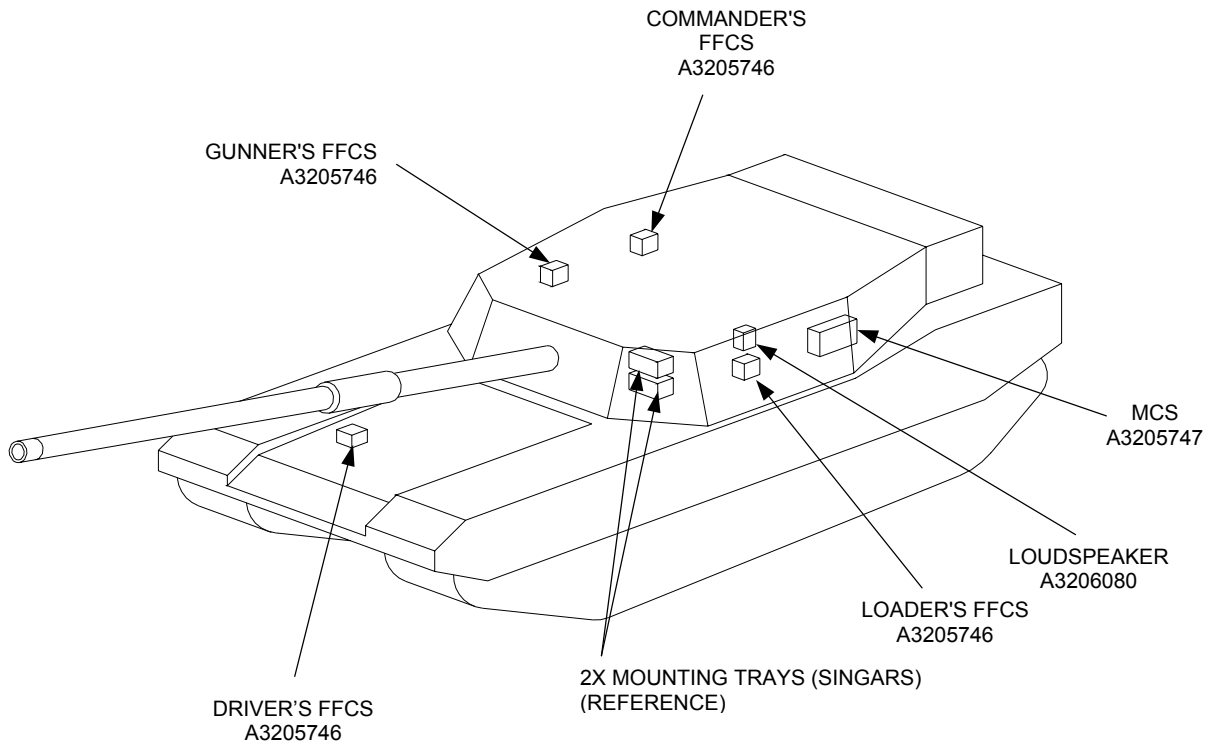
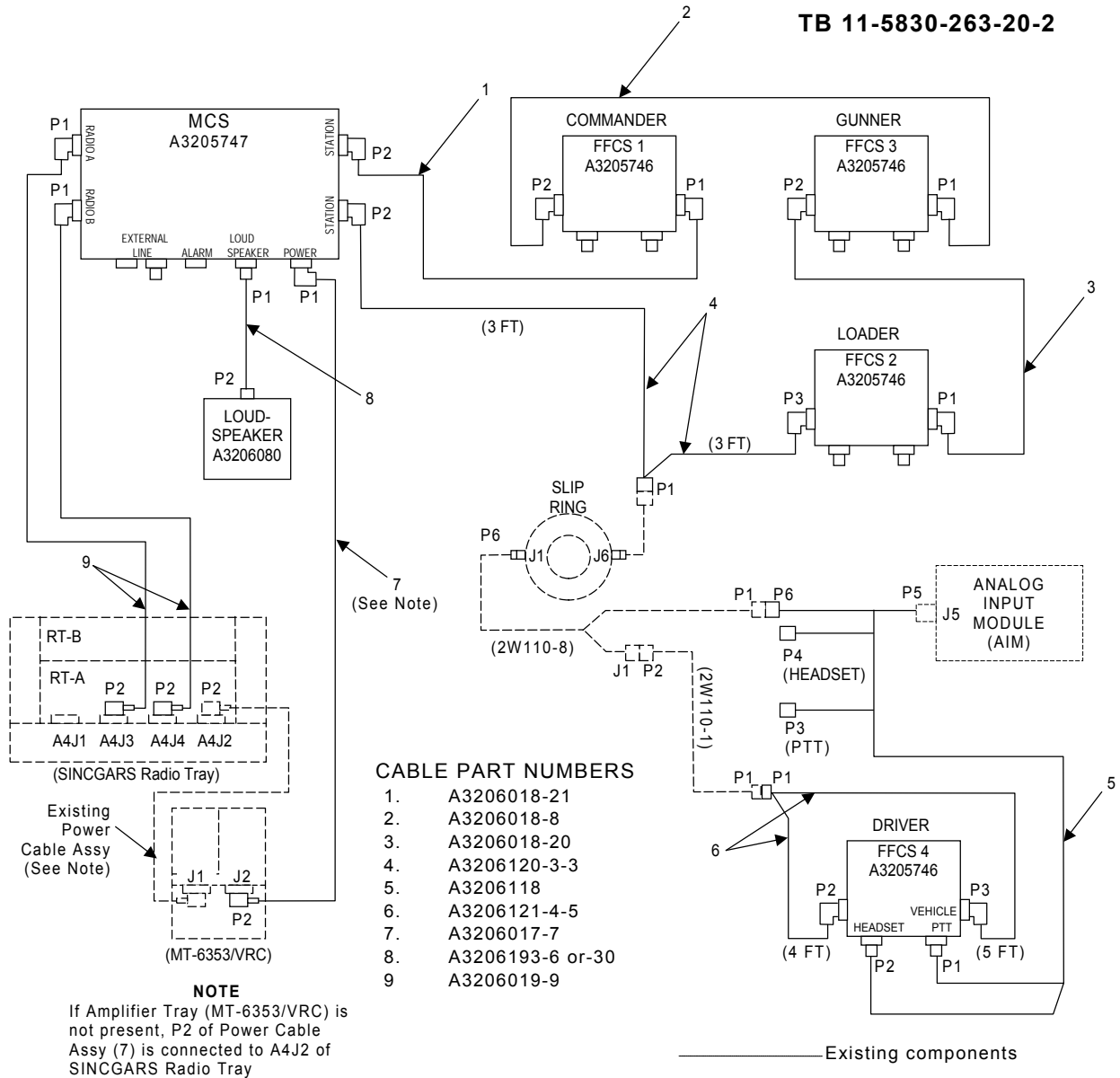

Figure 4-1. Equipment Location Diagram





Cable #	FROM			TO		
	Cable Conn.	Unit	Unit Conn.	Cable Conn.	Unit	Unit Conn.
9	P1	MCS	Radio A	P2	Radio Tray	A4J3
9	P1	MCS	Radio B	P2	Radio Tray	A4J4
7	P1	MCS	Power	P2	MT-6353/VRC	J2
8	P1	MCS	Loudspeaker	P2	Loudspeaker	
1	P2	MCS	Top Station	P1	FFCS #1	Right
2	P2	FFCS #1	Left	P1	FFCS #3	Right
3	P2	FFCS #3	Left	P1	FFCS #2	Right
4	P3	FFCS #2	Left	P1	Slip Ring Interface Cable	To Slip Ring J6
6	P1	2W110-1	From Slip Ring J1	P3	FFCS #4	Right
6	P2	FFCS #4	Left	P1	2W110-1	To Slip Ring J1
4	P1	Slip Ring Interface Cable	From Slip Ring J6	P2	MCS	Bottom Station
5	P1	FFCS#4	Vehicle PTT	P5	AIM	J5
5	P2	FFCS#4	Headset	P6	2W110-8	P1

Figure 4-2. System Configuration Diagram

**4.2 MASTER CONTROL STATION (MCS) INSTALLATION**

- a. Install and secure the MCS Mounting Bracket (5) to existing standoffs using existing hardware. While attaching the MCS mounting bracket use caution not to damage radio cable connectors against rear wall of turret. Transfer cables attached to back of previous mounting bracket to back of new MCS mounting bracket. Tag RF cables prior to removing.
- b. Install and secure the MCS (1) to MCS mounting bracket (5) as far to the right as possible. Secure using Items 2, 3 and 4 from Table 4-1 in the sequence(s) shown in Figure 4-3 and the following tools:

1/2 Inch Box or Open End Wrench

- c. Install and secure MCS Cover Assembly (6) using items 7 and 8 from Table 4-1 in the sequence(s) shown in Figure 4-3 and the following tools

Phillips Head Screwdriver

- d. Place the M1A2 decal (Item 9), on the MCS Cover Assembly (6) as shown in Figure 4-3.

**Table 4-1. MCS Installation Parts**

Item No.	Description	Qty	Part Number	NSN
1	MCS	1	A3205747	5895-01-382-3221
2	Nut, Hexagon	4	MS51968-5	5310-00-880-7746
3	Washer, Lock	4	MS35333-41	5310-00-167-0721
4	Washer, Flat	4	MS27183-12	5310-00-081-4219
5	MCS Mounting Bracket	1	A3206200	Not Applicable
6	MCS Cover Assembly	1	A3206103	Not Applicable
7	Screw, Pan Head	4	MS35206-263	5305-00-984-6210
8	Washer, Lock	4	MS35333-39	5310-00-576-5752
9	Decal, M1A2	1	A3206410	Not Applicable

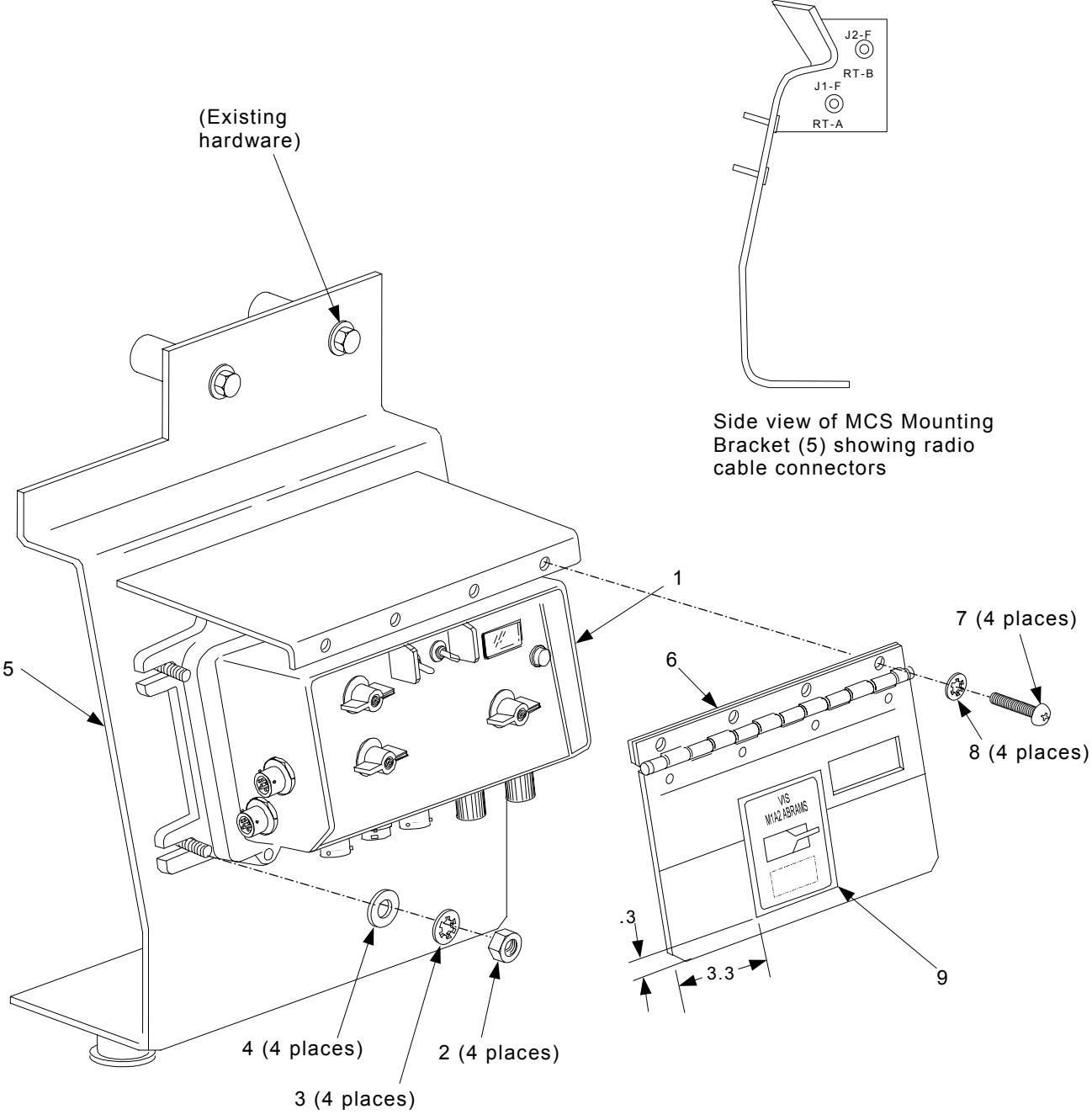

Figure 4-3. MCS Installation

**4.3 FULL FUNCTION CREW STATION (FFCS) INSTALLATION**

**a. Loader's FFCS Installation**

(1) Install and secure the Loader's FFCS/Loudspeaker bracket (5) to the roadside wall as shown in Figure 4-4, using existing hardware and the following tools:

1/2 Inch Box or Open End Wrench

(2) Install and secure the Loader's FFCS (1) to the Loader's FFCS/Loudspeaker bracket (5) in the sequence(s) shown in Figure 4-4 using the parts listed in Table 4-2 and the following tools:

1/2 Inch Box or Open End Wrench

(3) See Paragraph 4.6 for Loudspeaker Installation.

**Table 4-2. Loader's FFCS Installation Parts**

Item No.	Description	Qty	Part Number	NSN
1	FFCS	1	A3205746	5830-01-382-3218
2	Nut, Hexagon	2	MS51968-5	5310-00-880-7746
3	Washer, Lock	2	MS35333-41	5310-00-167-0721
4	Washer, Flat	2	MS27183-12	5310-00-081-4219
5	Loader's FFCS/Loudspeaker Bracket	1	A3206396	Not Applicable

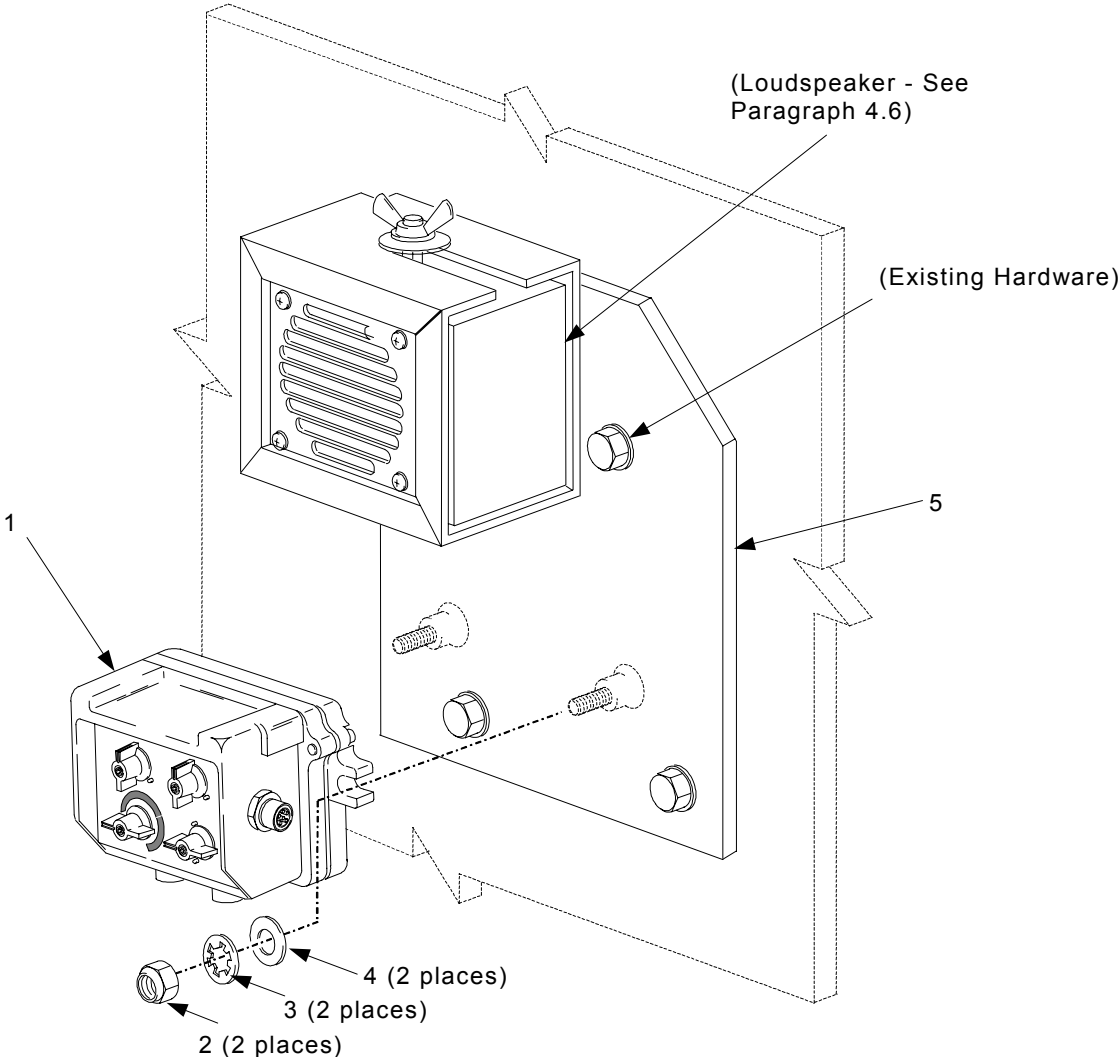

Figure 4-4. Loader's FFCS Installation

**4.3 FULL FUNCTION CREW STATION (FFCS) INSTALLATION (Continued)**

**b. Gunner's and Commander's FFCS Installation**

Install and secure the Mounting Plate (5) to the curbside wall as shown in Figure 4-5, using existing hardware and the following tools:

1/2 Inch Box or Open End Wrench

Install and secure FFCS (1) on the Mounting Plate (5) in the sequence(s) shown in Figure 4-5 using the parts listed in Table 4-3 and the following tools:

1/2 Inch Box or Open End Wrench

**Table 4-3. Gunner's and Commander's FFCS Installation Parts**

Item No.	Description	Qty	Part Number	NSN
1	FFCS	1	A3205746	5830-01-382-3218
2	Nut, Hexagon	2	MS51968-5	5310-00-880-7746
3	Washer, Lock	2	MS35333-41	5310-00-167-0721
4	Washer, Flat	2	MS27183-12	5310-00-081-4219
5	Plate, Mounting	1	A3206395	Not Applicable

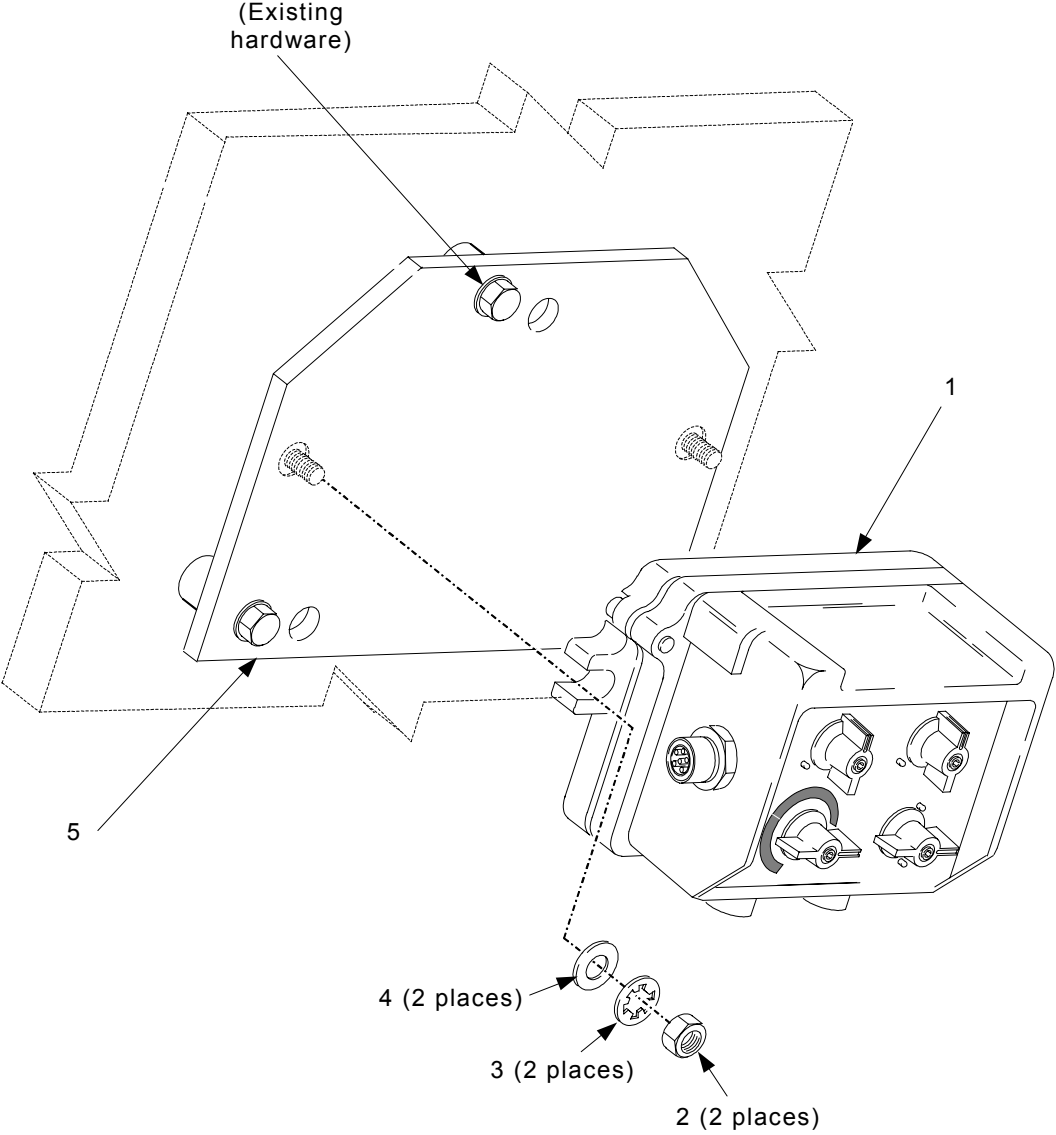

Figure 4-5. Gunner's and Commander's FFCS Installation

**4.3 FULL FUNCTION CREW STATION (FFCS) INSTALLATION (Continued)**

**c. Driver's FFCS Installation**

Install and secure the Driver's FFCS (1) and Bracket (8) to the curbside wall in the sequence(s) shown in Figure 4-6 using items 2, 3 and 4 from Table 4-4 and the following tools:

7/16 Inch Socket Wrench

Install and secure U-Bolt (7) on the Mounting Plate (8) in the sequence(s) shown in Figure 4-6 using Items 5 and 6 from Table 4-4 and the following tools:

1/4 Inch Socket Wrench

**Do not tighten U-Bolt hardware, leave loose.**

**Table 4-4. Driver's FFCS Installation Parts**

Item No.	Description	Qty	Part Number	NSN
1	FFCS	1	A3205746	5830-01-382-3218
2	Bolt, Machine	2	MS90725-8	5305-00-225-3839
3	Washer, Lock	2	MS35333-40	5310-00-550-1130
4	Washer, Flat	2	MS51412-4A	5310-00-103-6042
5	Nut, Lock	2	MS21042-3	5310-00-807-1467
6	Washer, Flat	2	MS27183-42	5310-00-014-5850
7	U-Bolt	1	NAS3103-6-8	5306-01-411-9027
8	Bracket, Mounting, Driver	1	A3206122	Not Applicable



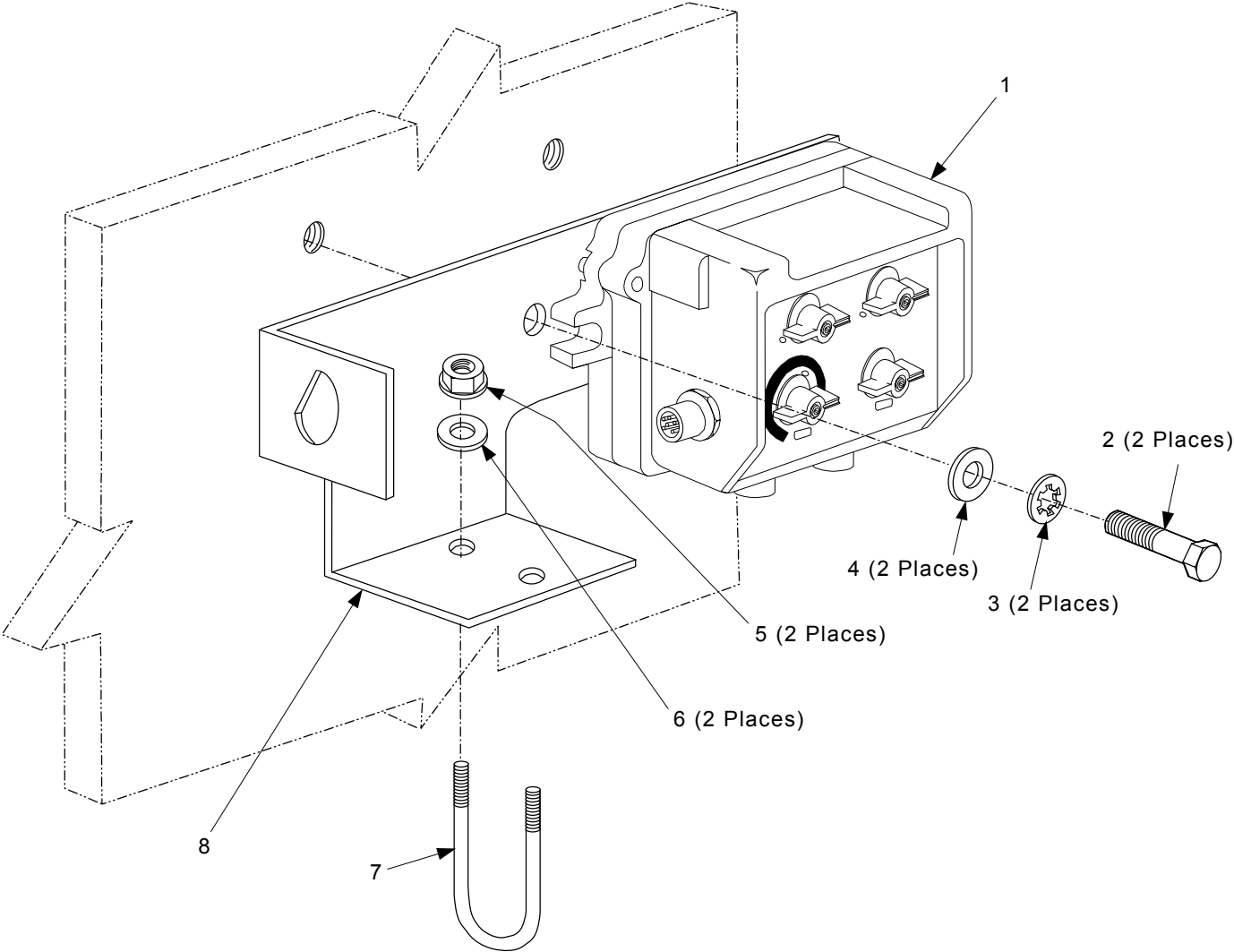

Figure 4-6. Driver's FFCS Installation

**4.4 RADIO INTERFACE TERMINAL (RIT) INSTALLATION**

This vehicle does not contain any RITs.

**4.5 MONITOR ONLY STATION (MOS) INSTALLATION**

This vehicle does not contain any MOS'.

**4.6 LOUDSPEAKER (LS) INSTALLATION**

Install and secure Loudspeaker to Loader's/Loudspeaker Bracket on the roadside wall by sliding loudspeaker shaft into bracket slot. Tighten wing nut by turning clockwise. See Figure 4-4.



## 4.7 VIS CABLING INSTALLATION

### Note

Where possible, run VIS cables along existing vehicle cable paths. Use existing cable clamps to hold VIS cables in place. If cable clamps are not large enough to hold VIS cables and vehicles cables, tie wrap VIS cables to clamped vehicle cables using tiedown straps supplied with kit, as required. During installation, leave tiedown straps loose enough to adjust cable slack and allow for easy adjustment of equipment. When installation is complete, tighten and secure tiedown straps. The cable strap supplied with kit is bolted to bosses on the vehicle wall at the locations shown using existing hardware. Cut Cable Strap to a length sufficient to bundle VIS cables and existing vehicle cables.

### WARNING

MAKE SURE VEHICLE POWER SOURCE IS POSITIONED OFF OR DISCONNECTED BEFORE INSTALLING CABLES.

#### a. MCS, Loader's FFCS and Loudspeaker Cabling Installation (Fig. 4-7)

1. The Loader's oddment tray must be temporarily removed from the turret roadside wall before running the cables. To remove the oddment tray, turn quick-release fastener and lift the tray away the wall. After all cables are positioned and fixed in place, and Section V Post Installation checks are completed, return the oddment tray to its original position. The cables must not interfere with the installation of this tray.
2. Secure connector P1 of the Radio R/T Cable Assembly (9) to the Radio A connector on the MCS (1).
3. Route the Radio R/T Cable (9) as shown in Figure 4-7, until the Radio Mounting Tray is reached.
4. Secure connector P2 of the Radio R/T Cable Assembly (9) to the Radio Mounting Tray connector A4J3.
5. Secure connector P1 of the Radio R/T Cable Assembly (9) to the Radio B connector on the MCS (1).
6. Route the Radio R/T Cable (9) as shown in Figure 4-7, until the Radio Mounting Tray is reached.
7. Secure connector P2 of the Radio R/T Cable Assembly (9) to the Radio Mounting Tray connector A4J4.
8. Secure connector P1 of the Power Cable Assembly (8) to the Power connector on the MCS (1).
9. Route the Power Cable Assembly (8) as shown in Figure 4-7, until the Amplifier Mounting Tray is reached.
10. Secure connector P2 of the Power Cable Assembly (8) to the Amplifier Mounting Tray connector J2. If Amplifier Mounting Tray is not present, secure to connector A4J2 of SINCGARS Radio Mounting Tray.
11. Secure connector P2 of the Highway/Vehicle Cable Assembly (2) to the bottom Station connector on the MCS (1).

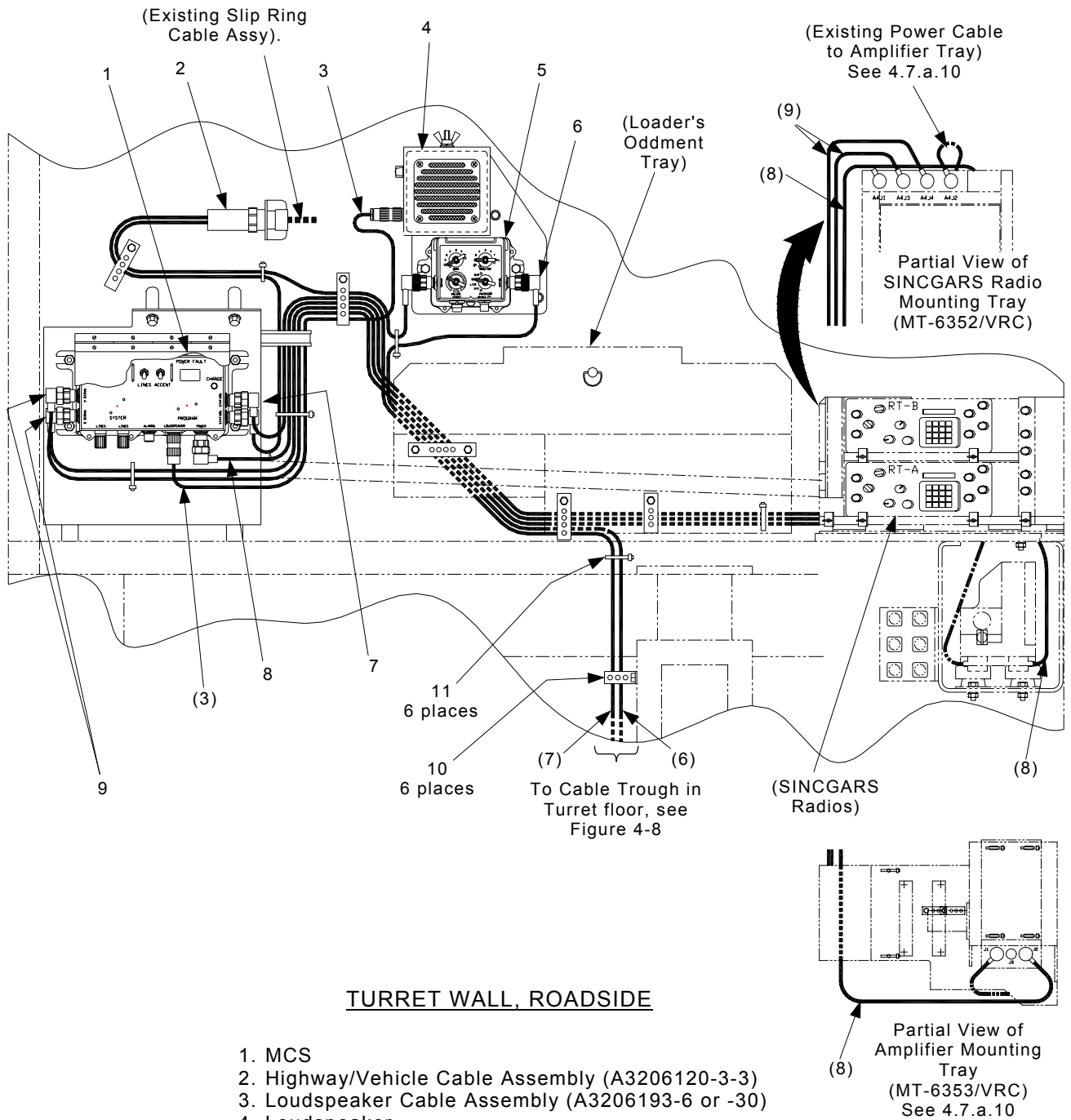

Figure 4-7. MCS, Loader's FFCS and Loudspeaker Cabling

**4.7 VIS CABLING INSTALLATION (continued)**

**a. MCS, Loader's FFCS and Loudspeaker Cabling Installation (Fig. 4-7)  
(continued)**

12. Route P1 leg of the Highway/Vehicle Cable Assembly (2) as shown in Figure 4-7, until the existing Slip Ring Cable Assembly is reached.
13. Secure connector P1 of the Highway/Vehicle Cable Assembly (2) to the Slip Ring Cable Assembly.
14. Route P3 leg of the Highway/Vehicle Cable Assembly (2) as shown in Figure 4-7, until the Loader's FFCS(5) is reached.
15. Secure connector P3 of the Highway/Vehicle Cable Assembly (2) to the left side Station connector of the Loader's FFCS (5).
16. Secure connector P1 of the Loudspeaker Cable Assembly (3) to the Loudspeaker connector on the MCS (1).
17. Route P2 of the Loudspeaker Cable Assembly (3) as shown in Figure 4-7, until the Loudspeaker is reached.
18. Secure connector P2 of the Loudspeaker Cable Assembly (3) to the Loudspeaker.
19. Secure connector P1 of the Highway Cable Assembly (6) to the right side Station connector of the Loader's FFCS (5).
20. Secure connector P2 of the Highway Cable Assembly (7) to the top Station connector on the MCS (1).
21. Route connector P2 of the Highway Cable Assembly (6) and connector P1 of Highway Cable Assembly (7) one at a time along roadside wall and down to cable trough located under the Loader's ammo box, firing gate support, and slip ring cover in turret floor as shown in Figures 4-7 and 4-8.



**4.7 VIS CABLING INSTALLATION (continued)**

**b. Turret Floor Cable Installation(Figure 4-8)**

1. Remove floor plates and slip ring cover to access cable troughs..
2. Locate cable troughs on roadside, curbside and turret floor.
3. Run Highway Cable Assemblies (1), (2) and Alarm Cable Assembly (3) along trough to curbside of vehicle as shown in Figure 4-8. Continue up conduit that extends from turret floor to Commander's joystick, see Figure 4-9.
4. Perform Section V Post Installation checks before replacing floor plates and slip ring cover.



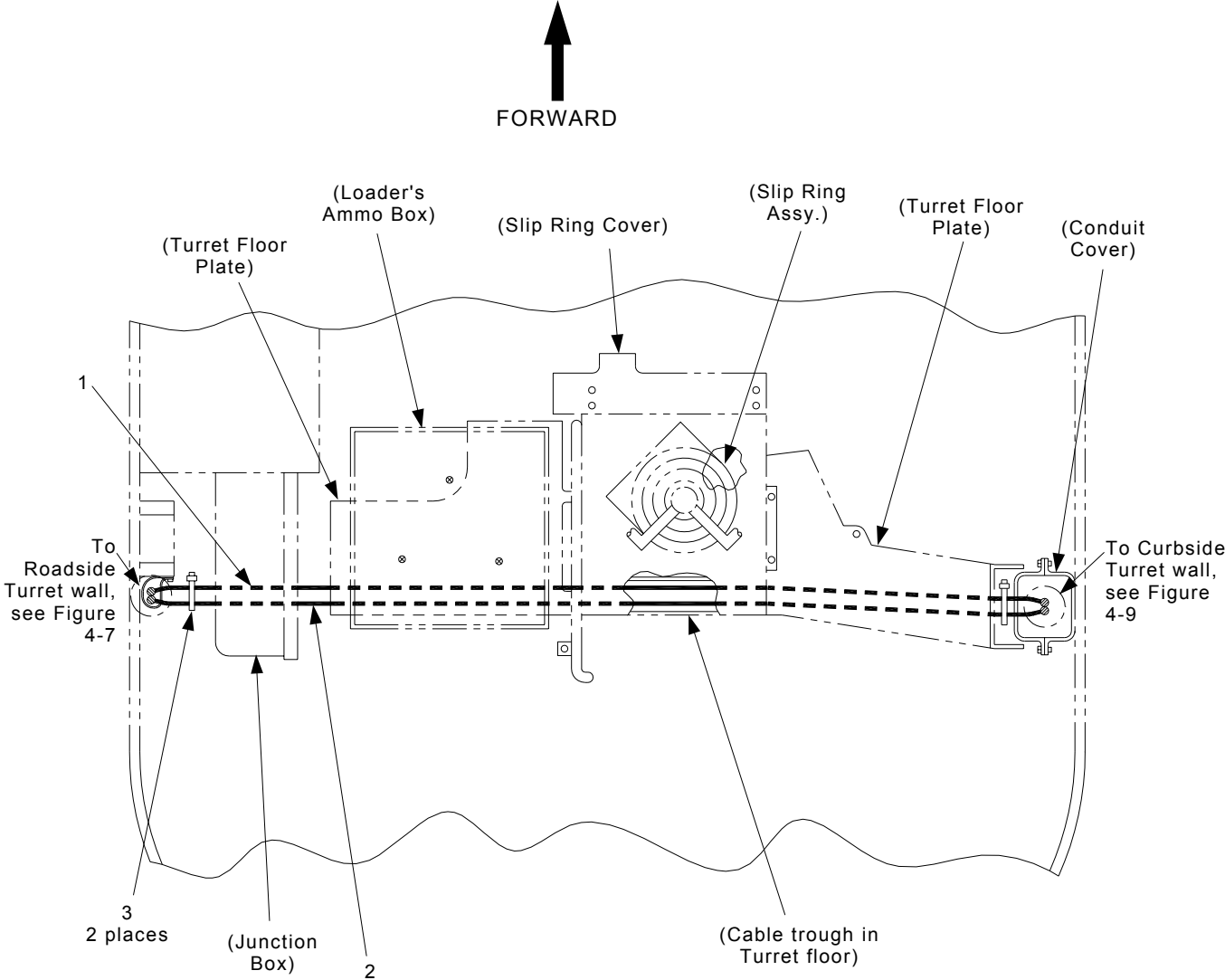

**TURRET FLOOR**

- 1. Highway Cable Assembly (A3206018-20)
- 2. Highway Cable Assembly (A3206018-21)
- 3. Tiedown Strap (MS3367-6-9)

**Figure 4-8. Turret Floor Cable Installation**

#### 4.7 VIS CABLING INSTALLATION (continued)

##### c. Gunner's and Commander's FFCS Cabling (Figure 4-9)

1. Secure connector P2 of the Highway Cable Assembly (1) from the Loader's FFCS to the left side Station connector of the Gunner's FFCS (2).
2. Secure connector P1 of the Highway Cable Assembly (5) from the MCS to the Right side Station connector on the Commander's FFCS (4).
3. Secure connector P1 of the Highway Cable Assembly (3) to the right side Station connector of the Gunner's FFCS (2).
4. Route Highway Cable Assembly (3) as shown in Figure 4-9 until the Commander's FFCS is reached.
5. Secure connector P2 of the Highway Cable Assembly (3) to the left side Station connector of the Commander's FFCS (4).

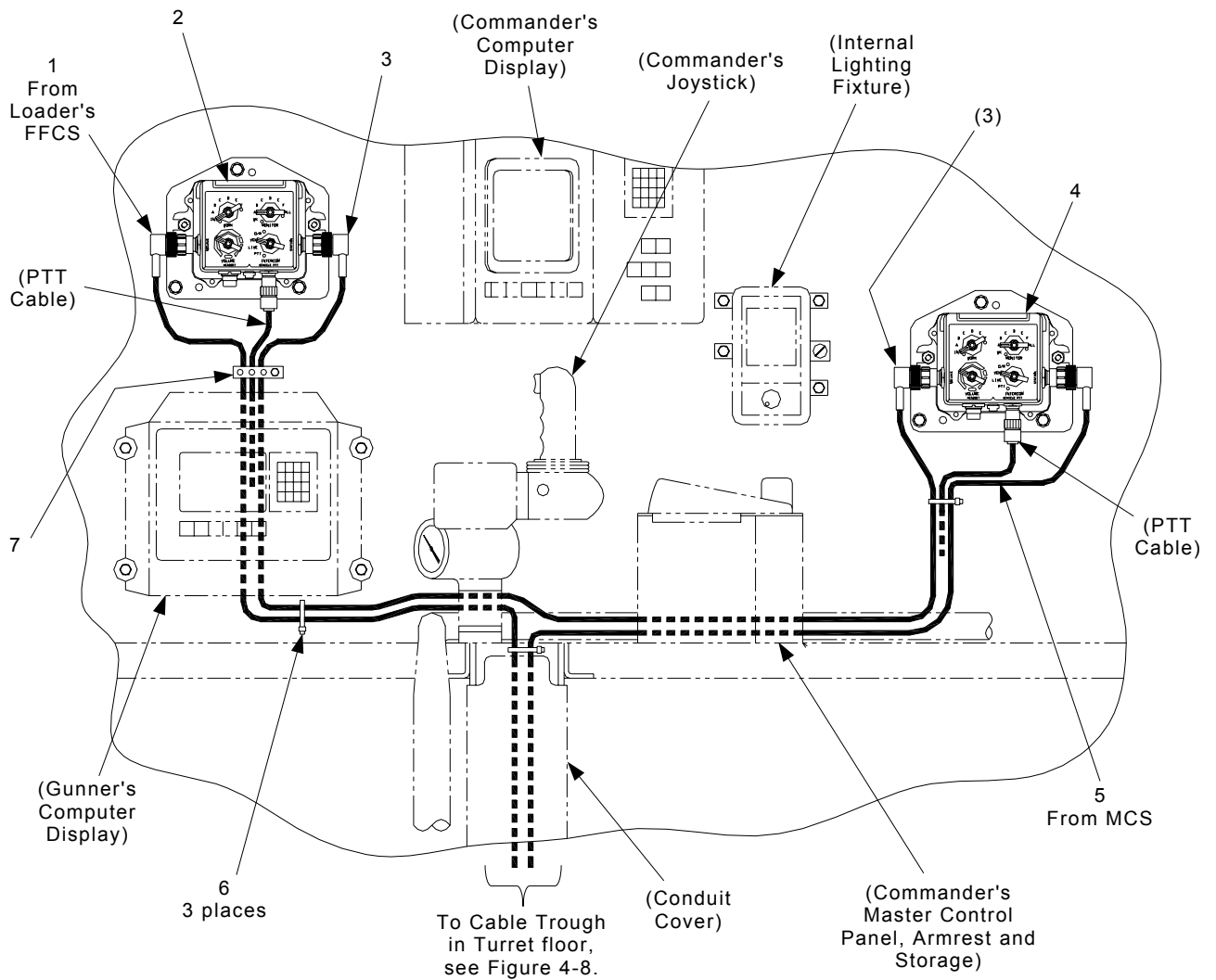

**TURRET WALL, CURBSIDE**

1. Highway Cable Assembly (A3206018-20)
2. Gunner's FFCS
3. Highway Cable Assembly (A3206018-8)
4. Commander's FFCS
5. Highway Cable Assembly (A3206018-21)
6. Tiedown Strap (MS3367-6-9)
7. Cable Strap (A3206207)

**Figure 4-9. Gunner's and Commander's FFCS Cabling**

**4.7 VIS CABLING INSTALLATION (continued)**

**WARNING**

DISCONNECTING OR BYPASSING THE VEHICULAR INTERCOMMUNICATION SYSTEM (VIS) ALARM CABLE CONNECTED TO THE DRIVER'S FULL FUNCTION CREW STATION (FFCS) BY THE VEHICLE CREWMAN IS PROHIBITED. SUCH ACTION MAY RESULT IN INJURY OR DEATH. EQUIPMENT DAMAGE MAY ALSO RESULT. THIS CABLE ENABLES THE VEHICLE HAZARD WARNING TONES TO BE INSERTED DIRECTLY INTO THE INTERCOM SYSTEM, SO THAT THESE WARNING TONES CAN BE INSTANTLY HEARD BY ALL OF THE VEHICLE CREWMEMBERS. ONLY THE UNIT MAINTAINER IS AUTHORIZED TO REMOVE AND REPLACE THE ALARM CABLE. REFER TO THE APPROPRIATE VIS TECHNICAL PUBLICATIONS FOR OPERATOR, INSTALLATION, AND MAINTENANCE INSTRUCTIONS.

**Note**

During vehicle operation tank crewmen are only authorized to disconnect the drop cord [attached to the left ear cup of the Combat Vehicle Crewman (CVC) Headset] from the Bailout Cable Assembly (Spaghetti Cord). This cable is connected directly to the VIS FFCS or Driver Alarm Cable. No other VIS cables may be removed/bypassed/replaced by the crewman. During PMCS only the Bailout Cable Assembly may be disconnected from the FFCS or Alarm Cable for cleaning and application of silicone gel to the connector O-ring. Upon completion of PMCS the Bailout Cable Assembly(s) should immediately be re-connected. Refer to the VIS Operator's Manual for instructions. All other maintenance should be referred to the Unit Maintainer.

**d. Driver's FFCS Cabling Installation (Fig. 4-10)**

1. Remove existing 2W110-8 cable connector from J5 of the Analog Input Monitor (AIM).
2. Secure connector P5 of Alarm Cable Assembly (2) to connector J5 of the AIM.
3. Secure connector P1 of existing 2W110-8 into P6 of Alarm Cable Assembly (2).
4. Secure connector P1 of Highway/Vehicle Assembly (3) to existing Slip Ring Cable Assembly, 2W110-1.
5. Route cable assemblies (2) and (3) as shown in Figure 4-10 to the Driver's FFCS (1).
6. Secure connector P3 of the Highway/Vehicle Cable Assembly (3) to the right side Station connector of the Driver's FFCS (1).
7. Secure connector P2 of the Highway/Vehicle Cable Assembly (3) to the left side Station connector of the Driver's FFCS (1).

8. Secure connector P3 of Alarm Cable Assembly (2) to the "D" hole on Driver's Mounting Bracket using attaching hardware.
9. Secure connector P4 of Alarm Cable Assembly (2) to Driver's Mounting Bracket using attaching U-Bolt previously installed. Orient P4 connector as shown in Figure 4-10.
10. Secure connector P1 of Alarm Cable Assembly (2) to VEHICLE PTT connector on Driver's FFCS (1).
11. Secure connector P2 of Alarm Cable Assembly (2) to the HEADSET connector on Driver's FFCS (1).



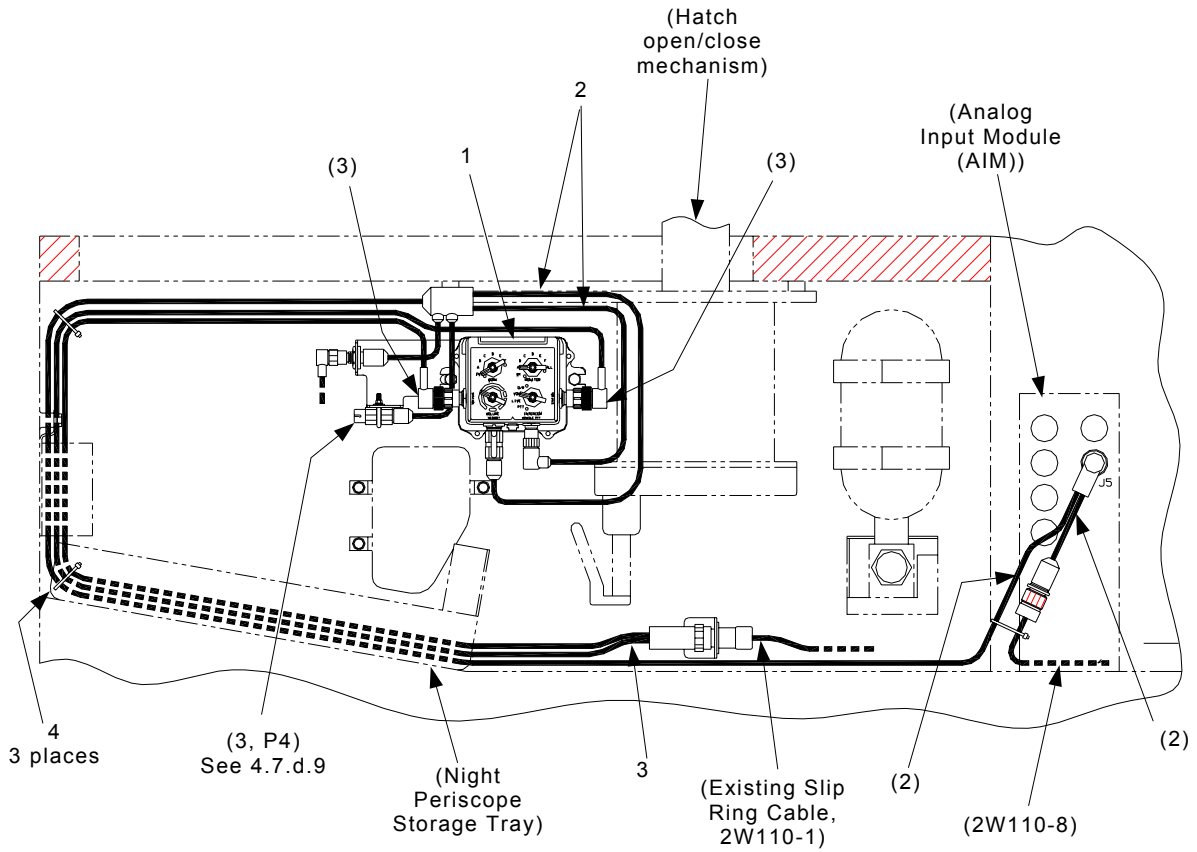

**DRIVER'S COMPARTMENT (CHASSIS), CURBSIDE**

1. Driver's FFCS
2. Alarm Cable Assembly (A3206118)
3. Highway/Vehicle Cable Assembly (A3206121-4-5)
4. Tiedown Strap (MS3367-6-9)

**Figure 4-10. Driver's FFCS Cabling**

## SECTION V. POST-INSTALLATION

### WARNING

DISCONNECTING OR BYPASSING THE VEHICULAR INTERCOMMUNICATION SYSTEM (VIS) ALARM CABLE CONNECTED TO THE DRIVER'S FULL FUNCTION CREW STATION (FFCS) BY THE VEHICLE CREWMAN IS PROHIBITED. SUCH ACTION MAY RESULT IN INJURY OR DEATH. EQUIPMENT DAMAGE MAY ALSO RESULT. THIS CABLE ENABLES THE VEHICLE HAZARD WARNING TONES TO BE INSERTED DIRECTLY INTO THE INTERCOM SYSTEM, SO THAT THESE WARNING TONES CAN BE INSTANTLY HEARD BY ALL OF THE VEHICLE CREWMEMBERS. ONLY THE UNIT MAINTAINER IS AUTHORIZED TO REMOVE AND REPLACE THE ALARM CABLE. REFER TO THE APPROPRIATE VIS TECHNICAL PUBLICATIONS FOR OPERATOR, INSTALLATION, AND MAINTENANCE INSTRUCTIONS.

#### Note

During vehicle operation tank crewmen are only authorized to disconnect the drop cord [attached to the left ear cup of the Combat Vehicle Crewman (CVC) Headset] from the Bailout Cable Assembly (Spaghetti Cord). This cable is connected directly to the VIS FFCS or Driver Alarm Cable. No other VIS cables may be removed/bypassed/replaced by the crewman. During PMCS only the Bailout Cable Assembly may be disconnected from the FFCS or Alarm Cable for cleaning and application of silicone gel to the connector O-ring. Upon completion of PMCS the Bailout Cable Assembly(s) should immediately be re-connected. Refer to the VIS Operator's Manual for instructions. All other maintenance should be referred to the Unit Maintainer.

### 5.1 POST-INSTALLATION CHECKOUT PROCEDURES

- a. Check that all LRU's are securely mounted.
- b. Verify that all cables are securely and correctly fastened and routed properly. Refer to Figure 4-2, System Configuration Diagram if needed.
- c. Tighten all tiedown straps and ensure that there is enough slack in the cables to allow for ease in disconnecting and connecting from the LRU's.
- d. Apply a small amount of silicone grease to the O-Ring in the bailout cable connector of the headset. Connect bailout cables to the bailout connectors of the vehicle headsets. Connect bailout cables to the HEADSET connector on the FFCS', and MOS' if present.



## 5.2 POST-INSTALLATION OPERABILITY VERIFICATION PROCEDURES

### Note

The following steps are simple go; no-go procedures to ensure that communication can be accomplished utilizing the LRU's and headsets. For actual programming instructions and for more thorough operating procedures refer to the VIS Operator's Technical Manual.

#### a. Setting the System Configuration on the MCS

1. On the MCS, set and hold the **PROGRAM** switch in the **STORE** position. While holding the **PROGRAM** switch in the **STORE** position depress and hold the **CHANGE** button.
2. While holding the **PROGRAM** switch in the **STORE** position and depressing the **CHANGE** button, set the **SYSTEM** switch in the **ALL** position.
3. Observe the display as it cycles through "\*\*\*\*", "**Pr15**", "**v07**" and "**cfig**". When "**cfig**" appears on the display release the **PROGRAM** switch and **CHANGE** button.
4. The display will show the system configuration, e.g. what FFCS' (1,2,3,4,5,6) and RITs (C/D, E/F) are connected as well as if the ring is connected.

### Note

Observing the display while the system configuration is being conducted allows the operator to cross check if the FFCS' and RIT's identification switch settings are correct. If there are four FFCS', with the address switch settings of 1 through 4, then the display should show "1c", "2c", "3c", and "4c". If a RIT or RITs are connected the display should show "Cc" or "Cc", "Dc", "Ec" and "Fc".

5. When system configuration has been completed, the display will show "**done**", immediately followed by "**Avhf**" with the "**vhf**" portion blinking. Holding the **PROGRAM** switch momentarily in the **STORE** position will program "**Avhf**" into the system configuration memory. Upon releasing the **PROGRAM** switch "**done**" will again appear on the display. "**Bvhf**" will then appear on the display with the "**vhf**" portion blinking.
6. Repeat the process for holding the **PROGRAM** switch momentarily in the **STORE** position for "**Bvhf**". If a RIT or RITs are connected, "**Cvhf**", "**Dvhf**", etc.; will also appear on the display. Simply repeat the process used for storing "**Avhf**" and "**Bvhf**" to the system configuration memory.
7. After the radios are stored in the system configuration memory the display will show "**test**", "**pass**", then "**ALL**". At this time turn the MCS **SYSTEM** switch to **OFF**.

#### b. FFCS and Headset Operability

### Note

Checking the operability of the FFCS' and Headsets requires two people.

1. Set the MCS **PROGRAM** switch on **SYSTEM** and the **SYSTEM** switch on **PROG 1**.
2. The system will initialize then start conducting Built-In-Test (BIT). The display will show "**test**" while BIT is being conducted.
3. If there are no configuration discrepancies or errors, the display shows "**pass**" followed immediately by the system mode "**P1**". If there are configuration discrepancies or errors, the display will show "**fail**", followed by error codes. If the display does show "**fail**" followed by the error codes, refer to the VIS Operator's Manual and/or Unit Maintenance Manual for troubleshooting and repair procedures.
4. Go to the first two FFCS' and put on the headsets connected to them. For both FFCS's, place the **WORK** switch on **INT**, the **MONITOR** switch on **WK**, and the **INTERCOM** switch on **PTT**.

**Note**

For the full procedures on FFCS, MOS, and Headset operations refer to the VIS Operator's Manual.

5. Communicate on the intercom by activating the headset or vehicle PTT switch. After intercom communication has been established, cycle through the **LIVE**, **VOX** and **O/R** functions of the FFCS **INTERCOM** switch as well as testing the operability of the Active Noise Reduction (ANR) switch (if present) and the PTT switch on the headsets.
6. Repeat these actions for all remaining FFCS' and Headsets, and MOS' if present. Additionally, test the Loudspeaker by placing the MCS **LOUDSPEAKER** switch on **INT** and communicating.
7. Upon completion of these procedures turn the MCS **SYSTEM** switch to **OFF**. The post-installation operability verification procedures are complete.

## APPENDIX A - REFERENCES

### A-1. SCOPE

This appendix lists forms, technical manuals, and miscellaneous publications that are either referenced in this technical bulletin or may be of use in installing and/or operating the Vehicular Intercommunication System (VIS).

### A-2. FORMS

DA Form 2028-2	Recommended Changes to Equipment Technical Publications
SF 361	Discrepancy in Shipment Report (DISREP)
SF 364	Report of Discrepancy (ROD)
SF 368	Product Quality Deficiency Report (QDR)

### A-3. TECHNICAL MANUALS

TM 11-5805-201-12	Operator's and Unit Maintenance Manual for Telephone Sets, TA-312/PT and TA-312A/PT
TM 11-5820-401-10-1	Operator's Manual for Radio Sets AN/VRC-12, AN/VRC-43, AN/VRC-44, AN/VRC-45, AN/VRC-46, AN/VRC-47, AN/VRC-48, and AN/VRC-49 (used without Intercom Systems)
TM 11-5820-401-10-2	Operator's Manual for Radio Sets, AN/VRC-12, AN/VRC-43, AN/VRC-44, AN/VRC-45, AN/VRC-46, AN/VRC-47, AN/VRC-48, and AN/VRC-49 (used with Intercom Systems)
TM 11-5820-401-20-1	Organizational Maintenance for Radio Sets, AN/VRC-12, AN/VRC-43, AN/VRC-44, AN/VRC-45, AN/VRC-46, AN/VRC-47, AN/VRC-48, and AN/VRC-49(used w/o Intercom Set)
TM 11-5820-401-20-2	Organizational Maintenance Manual for Radio Sets, AN/VRC-12, AN/VRC-43, AN/VRC-44, AN/VRC-45, AN/VRC-46, AN/VRC-47, AN/VRC-48, and AN/VRC-49 (used with Intercom Set AN/VIC-1(V))
TM 11-5820-890-10-3	Operator's Manual for Singgars Ground Combat Net Radio, Non-ICOM Manpack Radio AN/PRC-119, Short Range Vehicular Radio AN/VRC-87, Short Range Vehicular Radio (with Radio Mount) AN/VRC-87D, Short Range Vehicular Radio with Dismount AN/VRC-88, Short Range Vehicular Radio with Dismount (with Single Radio Mount) AN/VRC-88D, Short Range/Long Range Vehicular Radio AN/VRC-89, Long Range Vehicular Radio AN/VRC-90, Short Range/Long Range Vehicular Radio With Dismount AN/VRC-91, Long Range/Long Range Vehicular Radio AN/VRC-92

## **TB 11-5830-263-20-2**

TM 11-5820-890-10-8	Operator's Manual for Sincgars Ground Combat Net Radio, ICOM Manpack Radio, AN/PRC-119A, Short Range Vehicular Radio AN/VRC-87A, Short Range Vehicular Radio with Dismount AN/VRC-88A, Short Range/Long Range Vehicular Radio AN/VRC-88C, Short Range/Long Range Vehicular Radio AN/VRC-89A, Long Range Vehicular Radio AN/VRC-90A, Short Range/Long Range Vehicular Radio with Dismount AN/VRC-91A, Short Range/Long Range Vehicular Radio AN/VRC-92A used with Automated Net Control Device (ANCD)(AN-CYZ-10), Precision Lightweight GPS Receiver (PLGR)(AN/PSN-11) Secure Telephone Unit(STU) Frequency Hopping Multiplexer(FHMUX)
TM 11-5820-890-20-1	Unit Maintenance Manual for Ground ICOM Radio Sets AN/PRC-119A, AN/VRC-87A, AN/VRC-88A, AN/VRC-89A, AN/VRC-90A, AN/VRC-91A, AN/VRC-92A
TM 11-5820-890-20-2	Unit Maintenance Manual for Ground ICOM Radio Sets AN/PRC-119A, AN/VRC-87A, AN/VRC-87C, AN/VRC-88A, AN/VRC-89A, AN/VRC-90A, AN/VRC-91A, AN/VRC-92A (with Control, Receiver-Transmitter C-11561(C)/U(RCU))
TM 11-5820-890-20-3	Unit Level Maintenance Handbook Sincgars ICOM Ground Radios for Ground ICOM Radio Sets AN/PRC-119A, AN/VRC-87A, AN/VRC-88A, AN/VRC-89A, AN/VRC-90A, AN/VRC-91A, AN/VRC-92A
TM 11-5820-890-20-4	Unit Maintenance Manual (Non-ICOM Radio Sets)
TM 11-5820-923-12	Operator's and Organizational Maintenance Manual for Radio Set, AN/GRC-213
TM 11-5830-263-10	Operator's Manual for Vehicular Intercommunication Set AN/VIC-3(V)
TM 11-5830-263-20&P	Unit Maintenance Manual for Intercommunication Set, Vehicular AN/VIC-3(V)
TM 11-5830-340-12	Operator's and Unit Organizational Maintenance Manual for Intercommunication Set, AN/VIC-1(V) and Control, Intercommunication Set, C-10456/VRC
TM 746-10	General Packaging Instructions for Field Units
TM 750-244-2	Procedure for Destruction of Electronics Material to Prevent Enemy Use (Electronics Command)

### **A-4. MISCELLANEOUS PUBLICATIONS**

AMDF	Army Master Data File(Microfiche)
AR 55-38	Transportation Deficiency Report (TDR)
AR 380-5	Department of the Army Information Security Program
AR 710-2	Inventory Management Supply Policy Below the Wholesale Level
AR 725-50	Requisition, Receipt and Issue System
AR 735-11-2	Reporting of Item and Packaging Discrepancies

**A-4. MISCELLANEOUS PUBLICATIONS (continued)**

DA PAM 25-30	Consolidated Index of Army Publications (Microfiche)
DA PAM 710-2-1	Using Unit Supply System Manual Procedures as Contained in Unit Supply UPDATE
DA PAM 738-750	Maintenance Management Update
SB 11-131-2	Vehicular Radio Sets and Authorized Installations Volume II (Sincgars, FHMUX, and EPLRS)
SB 11-573	Painting and Preservation of Supplies Available for Field Use for Electronics Command Equipment





THEN . JOT DOWN THE INFO  
ABOUT IT ON THIS FORM.  
CAREFULLY TEAR IT OUT.  
FOLD IT AND DROP IT IN THE  
MAIL.

## SOMETHING WRONG WITH THIS PUBLICATION

FROM: (PRINT YOUR UNITS COMPLETE ADDRESS)  
Commander  
Stateside Army Depot  
A-I-I-N: AMSTA-US  
Stateside, N.J. 07703-5007

DATE SENT  
10 July 1975

PUBLICATION NUMBER  
TM 11-5840-340-12

PUBLICATION DATE  
23 Jan 74

PUBLICATION TITLE  
Radar Set AN/PRC-76

BE EXACT PIN-POINT WHERE IT IS

IN THIS SPACE TELL WHAT IS WRONG  
AND WHAT SHOULD BE DONE ABOUT IT:

PAGE NO	PARA GRAPH	FIGURE NO	TABLE NO
---------	------------	-----------	----------

2-25

2-28

Recommend that the installation antenna alignment procedure be changed throughout to specify a 20 IFF antenna lag rather than 10.

REASON: Experience has shown that with only a 10 lag, the antenna servo system is too sensitive to wind gusting in excess of 25 knots, and has a tendency to rapidly accelerate and decelerate as it hunts, causing stress to the drive train. Hunting is minimized by adjusting the lag to 20 without degradation of operation.

3-10

3-3

3-1

Item 5, Functional Test Plan. Change  $\square$  2 dB" to  $\square$  3 dB".

REASON: The adjustment procedure for the TRANS POWER FAULT indicator calls for a 3 dB (500 watts) adjustment to light the TRANS POWER FAULT indicator.

5-6

5-8

Change new step f.1 to read,  $\square$  Replace cover plate removed in step above."

REASON: To replace the cover plate.

FO-3

Zone C 3. On J1-2, change  $\square$  +24 VDC" to  $\square$  +5 VDC".

REASON: This is the output line of the 5 VDC power supply. +24 VDC is the input voltage.

TEAR ALONG DOTTED LINE

PRINTED NAME, GRADE OR TITLE AND TELEPHONE NUMBER

SSG I. M. DeSpirito 999-1776

SIGN HERE

FILL IN YOUR  
UNIT'S ADDRESS

FOLD BACK

DEPARTMENT OF THE ARMY



OFFICIAL BUSINESS

PLEASE  
AFFIX  
STAMP  
POSTAGE  
REQUIRED

**SAMPLE**

Commander  
U.S. Army Communications-Electronics Command  
and Fort Monmouth  
ATTN: AMSEL-LEO-D-CS-CFO  
Fort Monmouth, New Jersey 07703-5000

TEAR ALONG DOTTED LINE





# SOMETHING WRONG WITH THIS PUBLICATION

*THEN . JOT DOWN THE INFO  
ABOUT IT ON THIS FORM  
CAREFULLY TEAR IT OUT  
FOLD IT AND DROP IT IN THE  
MAIL.*

FROM: (PRINT YOUR UNIT'S COMPLETE ADDRESS)

DATE SENT

PUBLICATION NUMBER

PUBLICATION DATE

PUBLICATION TITLE

BE EXACT PIN-POINT WHERE IT IS

IN THIS SPACE TELL WHAT IS WRONG  
AND WHAT SHOULD BE DONE ABOUT IT:

PAGE  
NO

PARA  
GRAPH

FIGURE  
NO

TABLE  
NO

TEAR ALONG DOTTED LINE

PRINTED NAME, GRADE OR TITLE AND TELEPHONE NUMBER

SIGN HERE

FILL IN YOUR  
UNIT'S ADDRESS

FOLD BACK

DEPARTMENT OF THE ARMY

\_\_\_\_\_  
\_\_\_\_\_

OFFICIAL BUSINESS

PLEASE  
AFFIX  
STAMP  
POSTAGE  
REQUIRED

TEAR ALONG DOTTED LINE

**Commander  
U.S. Army Communications-Electronics Command  
and Fort Monmouth  
ATTN: AMSEL-LC-LEO-D-CS-CFO  
Fort Monmouth, New Jersey 07703-5000**

# SOMETHING WRONG WITH THIS PUBLICATION



*THEN . JOT DOWN THE INFO ABOUT IT ON THIS FORM. CAREFULLY TEAR IT OUT. FOLD IT AND DROP IT IN THE MAIL.*

FROM: (PRINT YOUR UNIT'S COMPLETE ADDRESS)

DATE SENT

PUBLICATION NUMBER

PUBLICATION DATE

PUBLICATION TITLE

BE EXACT PM-POINT WHERE IT IS

IN THIS SPACE TELL WHAT IS WRONG AND WHAT SHOULD BE DONE ABOUT IT:

PAGE NO

PARA GRAPH

FIGURE NO

TABLE NO

TEAR ALONG DOTTED LINE

PRINTED NAME, GRADE OR TITLE AND TELEPHONE NUMBER

SIGN HERE

FILL IN YOUR  
UNIT'S ADDRESS

FOLD BACK

DEPARTMENT OF THE ARMY

\_\_\_\_\_  
\_\_\_\_\_

OFFICIAL BUSINESS

PLEASE  
AFFIX  
STAMP  
POSTAGE  
REQUIRED

TEAR ALONG DOTTED LINE

**Commander**  
**U.S. Army Communications-Electronics Command**  
**and Fort Monmouth**  
**ATTN: AMSEL-LC-LEO-D-CS-CFO**  
**Fort Monmouth, New Jersey 07703-5000**

# SOMETHING WRONG WITH THIS PUBLICATION



THEN... JOT DOWN THE INFO ABOUT IT ON THIS FORM. CAREFULLY TEAR IT OUT. FOLD IT AND DROP IT IN THE MAIL.

FROM: (PRINT YOUR UNIT'S COMPLETE ADDRESS)

DATE SENT

PUBLICATION NUMBER

PUBLICATION DATE

PUBLICATION TITLE

I

BE EXACT PIN-POINT WHERE IT IS

IN THIS SPACE TELL WHAT IS WRONG AND WHAT SHOULD BE DONE ABOUT IT:

PAGE NO

PARA GRAPH

FIGURE NO

TABLE NO

TEAR ALONG DOTTED LINE

PRINTED NAME, GRADE OR TITLE AND TELEPHONE NUMBER

SIGN HERE

FILL IN YOUR  
UNIT'S ADDRESS

FOLD BACK

DEPARTMENT OF THE ARMY

PLEASE  
AFFIX  
STAMP  
POSTAGE  
REQUIRED

OFFICIAL BUSINESS

**Commander**  
**U.S. Army Communications-Electronics Command**  
**and Fort Monmouth**  
**ATTN: AMSEL-LC-LEO-D-CS-CFO**  
**Fort Monmouth, New Jersey 07703-5000**

TEAR ALONG DOTTED LINE

By Order of the Secretary of the Army:

Official:

  
JOEL B. HUDSON  
*Administrative Assistant to the  
Secretary of the Army*  
0022304

ERIC K. SHINSEKI  
*General, United States Army  
Chief of Staff*

DISTRIBUTION:

To be distributed in accordance with the initial distribution number (IDN) 369721 and special requirements for TB 11-5830-263-20-2.

